

# EOLIS WIREFREE RTS SENSOR

## Operating Instructions

### DESCRIPTION

The Eolis WireFree RTS Sensor is a battery powered, 2-axis vibration sensor that detects vibration of an awning caused by excessive wind. It will transmit a radio command to retract an awning when the vibration due to wind is greater than the set point. It comes packaged in a weather proof enclosure and is meant to mount on the front bar of the awning.

### OPERATING INSTRUCTIONS

#### System Set Up

1. Apply power to a motorized awning already installed on a dwelling.
2. Press the UP button on a Telis or similar transmitter already memorized. The awning should retract. If this is incorrect, follow the directions included with the transmitter to reverse the motor direction. **FAILURE TO CORRECT THIS ERROR WILL CAUSE THE AWNING TO EXTEND DURING WINDY CONDITIONS AND MAY CAUSE SERIOUS DAMAGE.**
3. Measure the time it takes the awning to travel from fully retracted to fully extended. Set Dip Switch 2 to the ON position for travel time between 60 and 90 seconds. Set Dip Switch 2 to the OFF (near the battery) position for travel time less than 60 seconds.
4. Put the RTS motor in programming mode by depressing the program button on the original transmitter. The motor should jog. Push the programming button on the sensor. The motor will jog again, the sensor is now memorized by the motor. Repeating this step will remove the sensor from the motor memory.
5. Disconnect the awning from power. Secure the cover to the Eolis Sensor with the screws provided. Mount the sensor to the awning using the hardware provided.
6. Once the sensor is properly mounted, reconnect power to the awning. Fully extend the awning using a Telis Transmitter. After 15 seconds, jolt the front bar to simulate a windy condition. The awning should retract.

#### Setting the Sensitivity

The Eolis Wirefree Sensor is shipped with the most sensitive settings. If it is determined that the awning is retracting too often or due to minimal wind, the sensitivity can be decreased by turning each adjustment knob counter clockwise. It is recommended the set point be decreased in increments of two and the sensor retested.

#### Operation

1. When the awning extends, the sensor will ignore any vibrations for the period of time set in Dip Switch 2.
2. When the wind is strong enough to cause the awning to vibrate, the sensor will retract the awning. All commands will be ignored for a period of one minute afterwards.
3. If the awning is stopped before extending fully and a subsequent down command is given, the Eolis WireFree Sensor will view the movement as a wind vibration and retract the awning. The user will have to wait up to 30 seconds before the awning can be activated again.

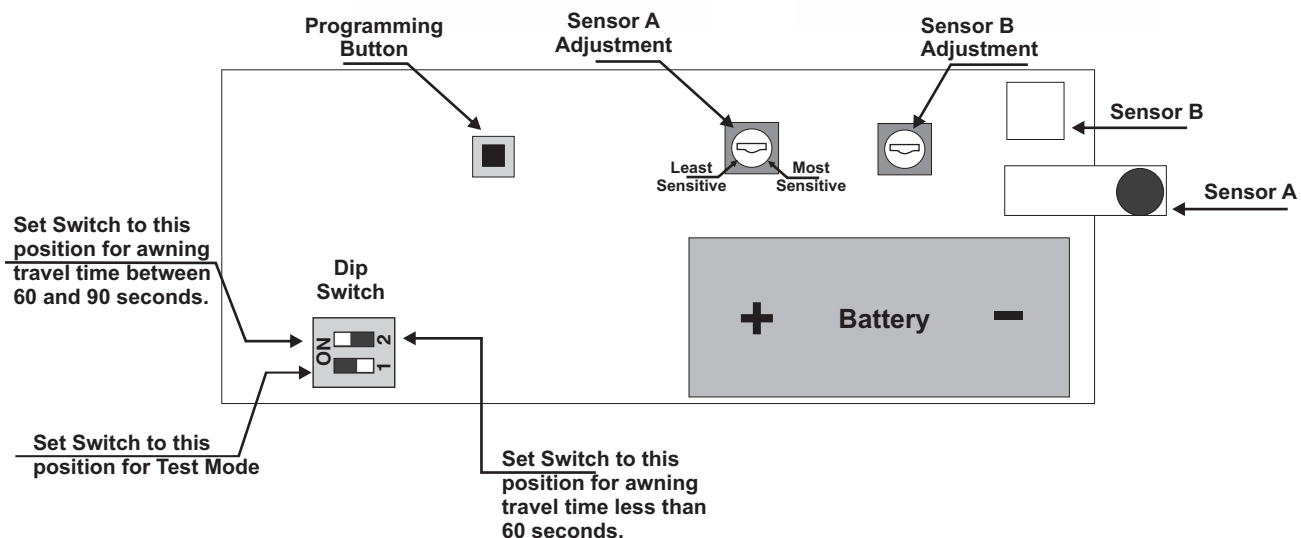

## TEST MODE

1. Set Dip Switch 1 to the ON position. The 60/90 second delay is not active.
2. The awning can be extended manually using the Telis transmitter. Jolt the front bar twice within 10 seconds to simulate a windy condition.
3. The awning will begin to retract. It can be manually operated again after 5 seconds.
4. When testing is complete, it is important to return Dip Switch 1 to the OFF position (toward the battery).

## MOUNTING CONSIDERATIONS

With the awning extended, the Eolis Wirefree Sensor must be mounted either horizontally or vertically, not at an angle. The preferred mounting location is under the awning using the slots under the front bar, tabs and flat head screws are provided. The awning arms should be used as a last resort. If the sensor must be mounted on the awning arms, be sure to avoid damaging the internal cables when using the self drilling screws. Care must be exercised, particularly with cassette awnings, to make sure the sensor is not crushed when the awning is retracted. For proper operation, the awning should be rigidly mounted to avoid excessive vibration.

## TROUBLE SHOOTING NOTES

- If the Eolis Wirefree Sensor is removed from the awning, but not the motor memory, the awning will keep retracting every hour.
- If the battery is near discharged, the awning will retract and cannot be operated until the battery is replaced
- When replacing the battery, be sure the polarity is respected. If the battery is inserted incorrectly, the battery will get quite hot and the Wirefree Sensor will not operate.

## MECHANICAL SPECIFICATIONS

Overall Dimensions: L: 4 in. W: 1 <sup>3</sup>/<sub>4</sub> in. D: 1 <sup>1</sup>/<sub>4</sub> in.

Frequency Range (optimal conditions): 25 ft.

## ELECTRICAL SPECIFICATIONS

Power: 3V Lithium battery, Cr123A

Frequency: 433.42 Mhz

## ORDERING INFORMATION

| Description        | Part Number |
|--------------------|-------------|
| White Enclosure    | 9013911     |
| Sand Enclosure     | 9013993     |
| Brown Enclosure    | 9013994     |
| 3v Lithium Battery | 56700160    |

### FCC Information

This device complies with Part 15 of the FCC Rules. Operation is subject to the following two conditions:

1. This device may not cause harmful interference, and
2. This device must accept any interference received, including interference that may cause undesired operation.

Note: This equipment has been tested and found to comply with the limits for a CLASS B digital device, pursuant to Part 15 of the FCC rules. These limits are designed to provide reasonable protection against harmful interference when the equipment is operated in a commercial environment. This equipment generates uses and can radiate radio frequency energy and, if not installed and used in accordance with the instructions, may cause harmful interference to radio communications. However, there is no guarantee that interference will not occur in a particular installation. If this equipment does cause harmful interference to radio or television reception, which can be determined by turning the equipment off and on, the user is encouraged to try and correct the interference by one or more of the following measures:

- 1.1 Reorient or relocate the receiving antenna.
- 1.2 Increase the separation between the equipment and receiver.
- 1.3 Connect the equipment into an outlet on a circuit different from that to which the receiver is connected.
- 1.4 Consult the dealer or experienced radio/TV technician for help.

### SOMFY CANADA

6315 Shawson Drive, Unit #1  
Mississauga, Ontario L5T1J2

### SOMFY SYSTEMS, INC.

47 Commerce Drive  
Cranbury, NJ 08512

### SOMFY MEXICO S.A. De C.V.

Calle 3 No.47, Loc.E-5  
Fracc Ind. Alce Blanco  
Nau.,Edo. de Mex C.P. 53370,Mex

SOMFY SYSTEMS, INC. reserves the right to change, update or improve this document without prior notice.

Ref. No. 2500911

© SOMFY SYSTEMS, INC. 3/07