



CTS40

Fabrication Instructions

DESCRIPTION

The patented Cord Take-Up System (CTS) for Horizontal Blinds, enables the lift and tilt functions and prevents cord slippage, tangling and overlap. By using the Cord Take-Up System versus a tape, you achieve increased product reliability, smoother and more uniform operation and

eliminate unsightly tapes that don't match horizontal blind colors. What's more, manufacturing and assembling horizontal blinds with cords is an easier process.

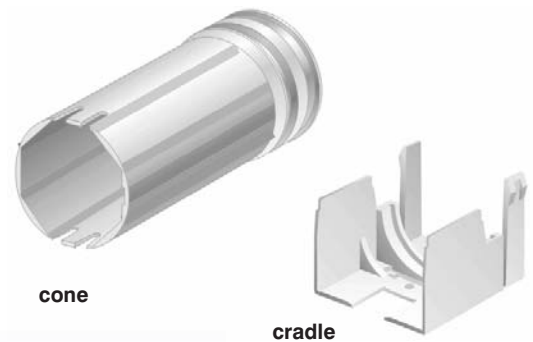

COMPONENTS

- Motor 400's (404 S2, 404 R2, 408 R2, 401 F2)
- Octagonal Crown and Drive Kit (# 6061289)
- Motor/Idler Brackets x (2) (#6080251)
- Tube 40mm Octagonal (# 6050521)
- End Cap 40mm Octagonal (# 6090186)
- CTS 40 Cone and Cradle Kit (#6180391)

RECOMMENDED HEADRAIL:

57mm x 51mm

Hunter Douglas, Perma Turnils, Graber etc...

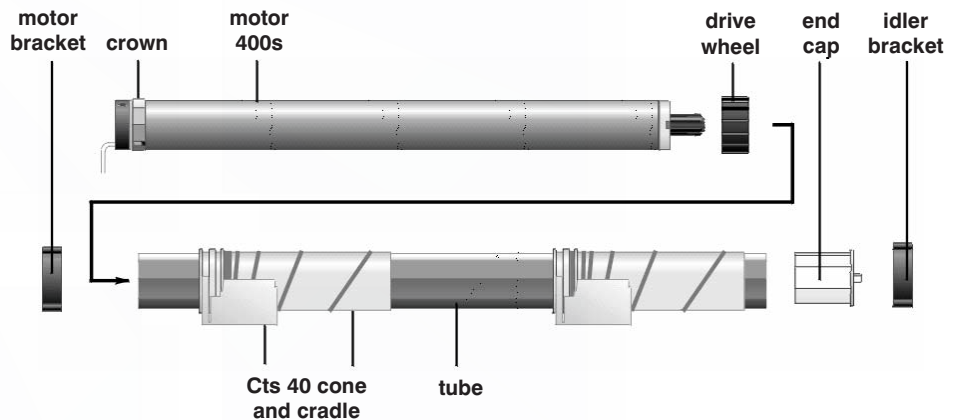

TECHNICAL SPECIFICATIONS

	Maximum lifting capacity (lbs.)	Maximum area for 50 mm Aluminum blinds (sq. ft.)	Maximum area for 50 mm Wood blinds (sq. ft.)	Maximum height with \varnothing 2 mm cord (ft.)	Operator speed (RPM)
404 S2	21	102	46	13	30
404 R2	21	102	46	13	16
409 R2	42	172	92	13	16
401 F2	7	35	15	13	64

* Specifications based on motors used with (CTS). They are approximate and may vary depending on product and application.

ASSEMBLY INSTRUCTIONS

A. Headrail Preparation

1. Cut or specify headrail width that is suitable for blind or shade application.
2. Cut or punch headrail to accommodate CTS 40 cradle. The illustrations below portray two different examples of headrail punches.

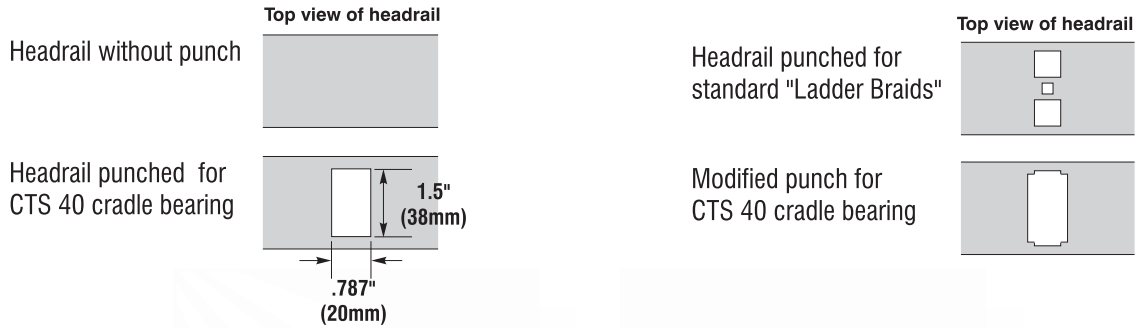

*SOMFY can provide Tool and Die to enable accurate punching for CTS components. Contact our sales group for pricing and availability.

3. Drill the holes necessary for the motor and plug end and for access to the limit switch screws.

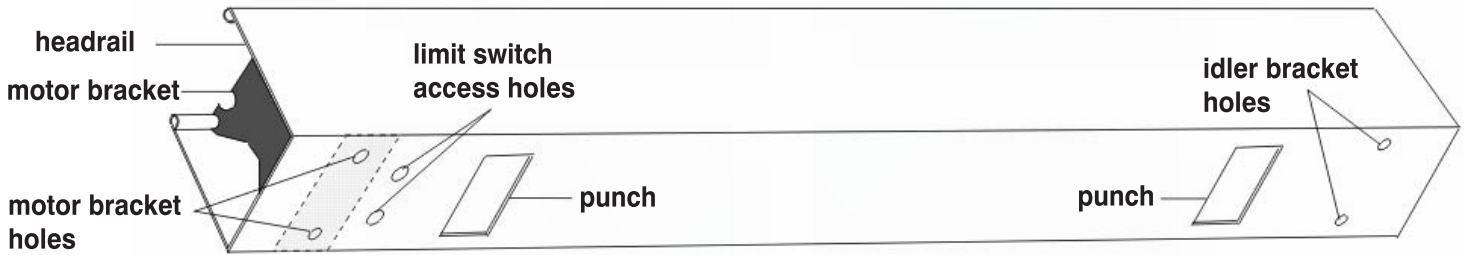

See dimensions below

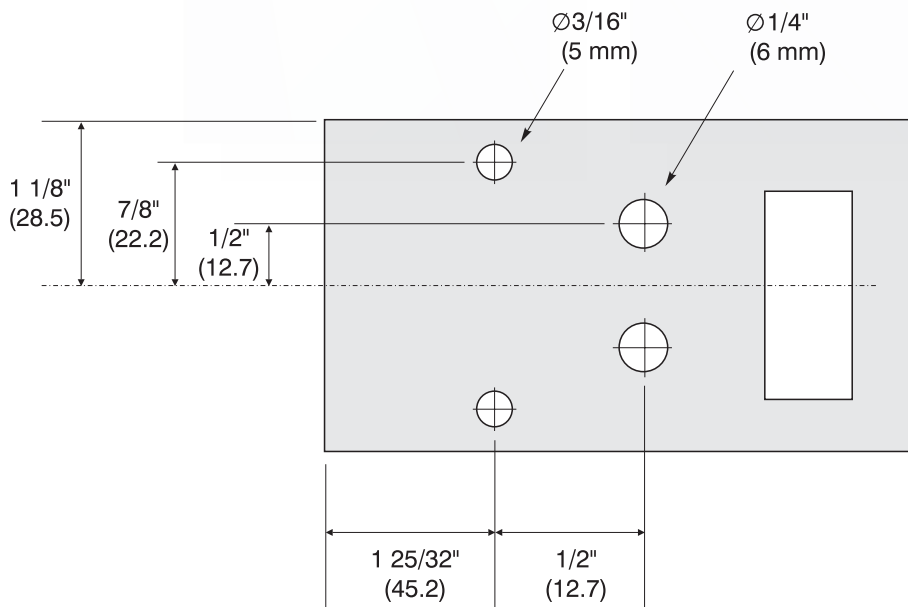

B. Motor and Tube Preparation

1. Cut 40mm octagonal tube to appropriate length for application.
 * Take-up cords that are 6" from end of headrail (Max length of tube = headrail length - 4 7/8")

2. Insert 40mm octagonal end cap into end of tube.



3. Attach 40mm crown and drive adaptors to motor.

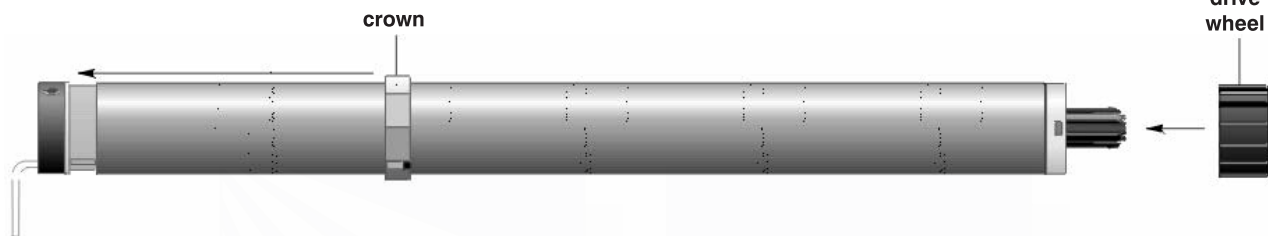

4. Insert motor and adaptors into 40mm octagonal tube.

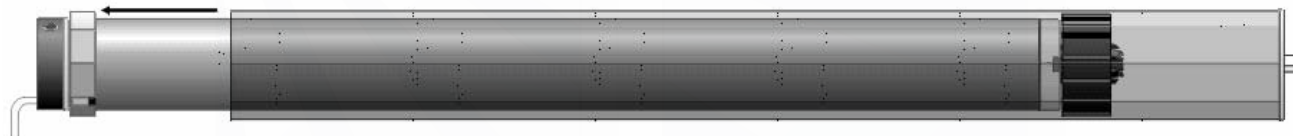

5. Fasten motor bracket to motor.

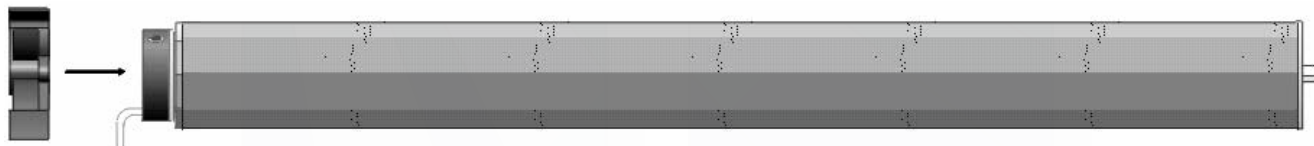

C. Ladder Braid Assembly

1. Cut the ladder braids according to the slats width
2. Fasten ladder grip to create a loop (see illustration).

SLATS WIDTH	25mm	35mm	50mm
LADDER LENGTH (X)	195mm	200mm	210mm

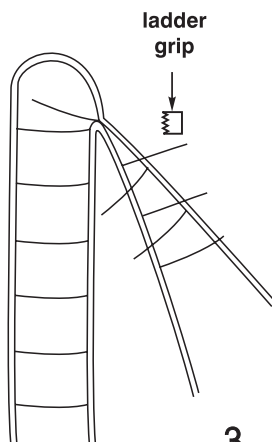
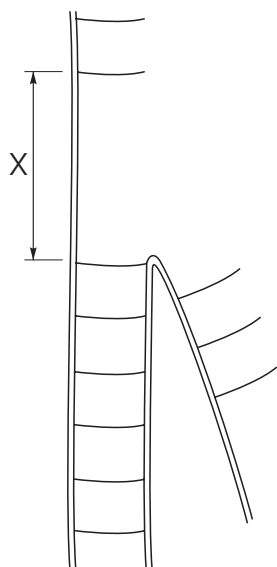

3

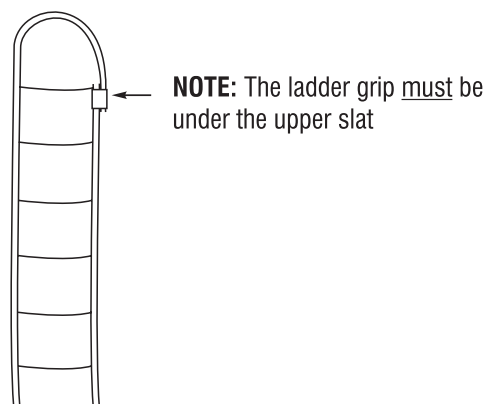

D. Cradle Bearing Assembly

1. Insert cradle bearing into headrail.
It is recommended that all cradle bearings are positioned in the same direction.

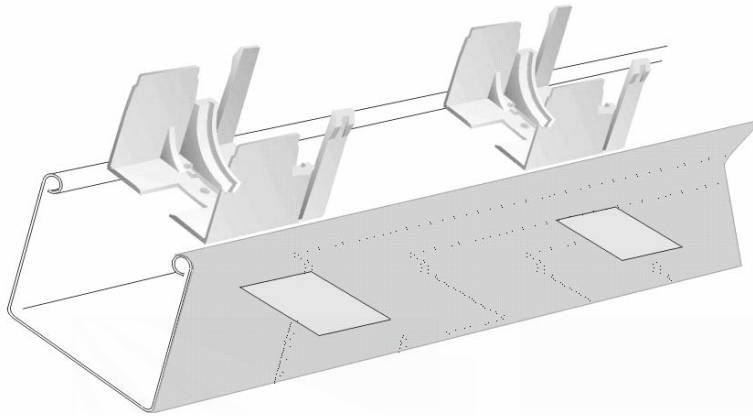

Headrail

2. Feed the take-up cords through the center holes of the cradle bearings as illustrated below.
Be sure the cord is positioned in relation to the ladder braid.

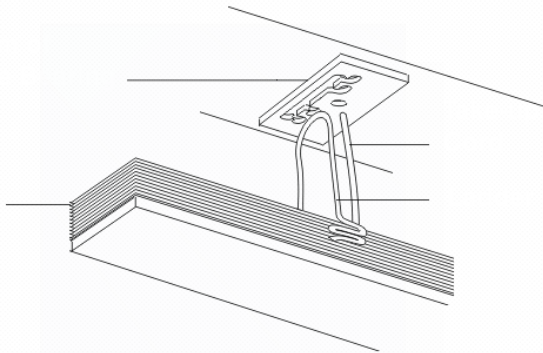
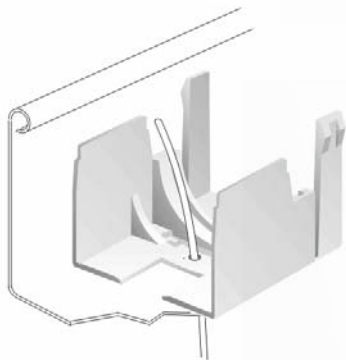

3. Feed ladder braids through cradle bearings. Outermost holes accommodate larger width slats, i.e. 2".

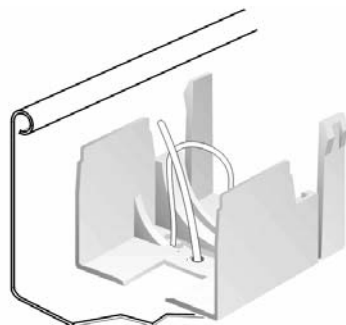

See Detail

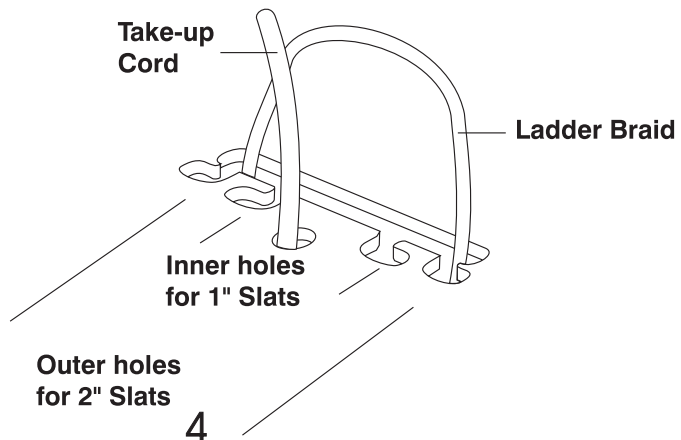

E. Cone Assembly

1. With the take-up cord resting over the edge of the headrail, position the cone over the cradle bearing and slide ladder braid over the cone and into the groove as shown below.
2. Press cone into headrail and position into cradle bearing.



3. Rotate each cone and align for tube insertion.

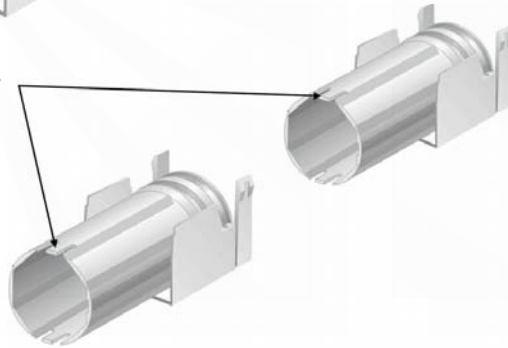

F. Motor and Tube Insertion

1. Insert the idler end bracket into the headrail and align with pre-drilled holes.

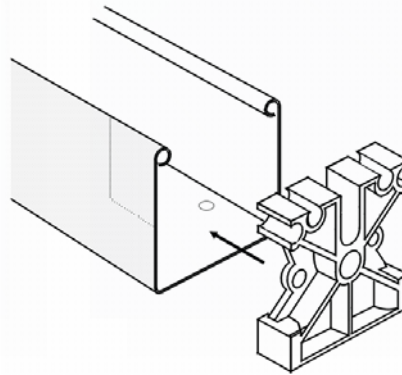

2. With the cones in proper alignment insert motor assembly into the headrail and cones.

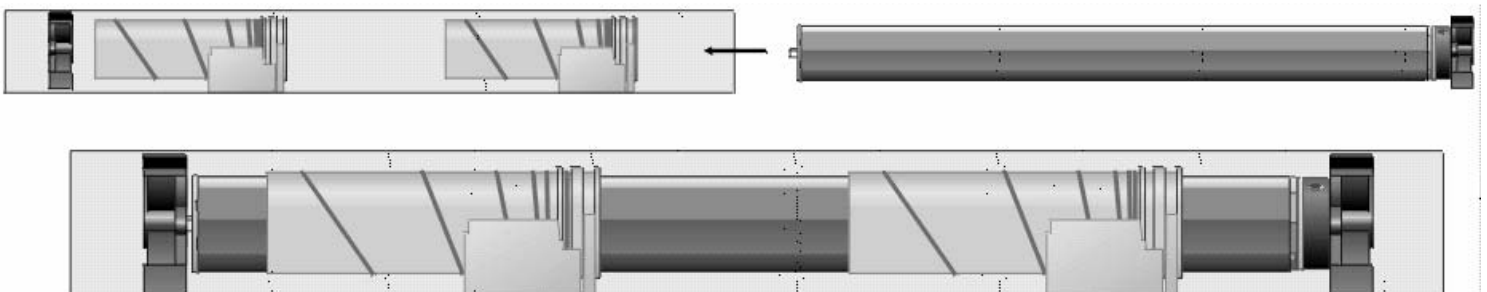

G. Securing Take-up Cords

1. Temporarily hang the blind and extend slats to a "lowered position." (be certain take-up cords remain accessible.)
2. With blind hanging in a "lowered position" carefully mark each take-up cord with regard to each cone (see detail)

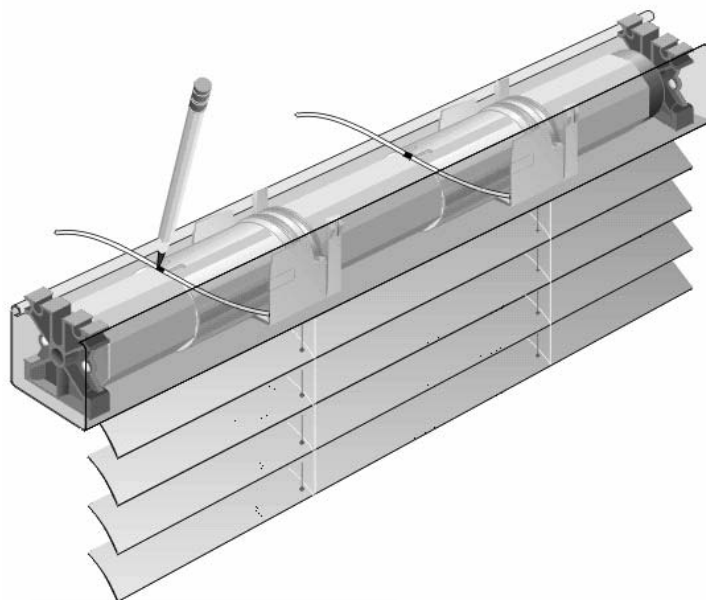

3. Tie a knot at the mark on each cord and fasten to each cone respectively.

Marked Take-up Cord

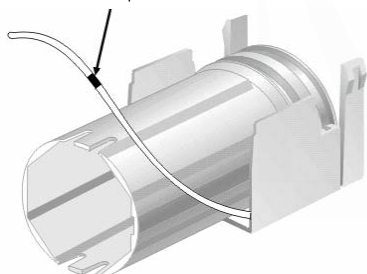

Knot Tied at Mark

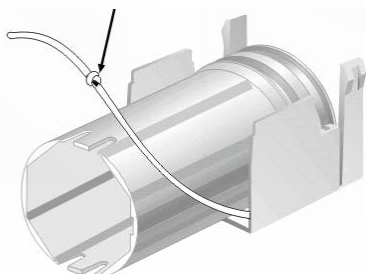

Detail of Knot Attached to Cone

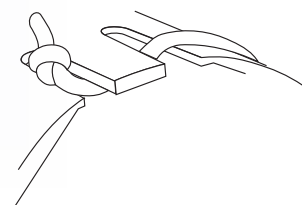

4. Fasten motor bracket and idler bracket to headrail using (#10 x 3/8" screws) or (5/32" x 3/8" poprivets)

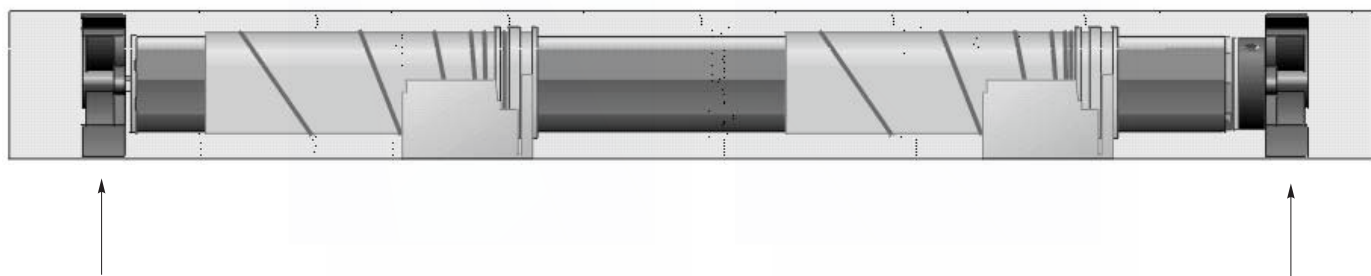

H. Final Adjustments

1. Apply power and run the blind in the up or down direction. Adjust the travel distance by turning the limit screws. (See limit switch adjustment instructions included with motor.)
2. Adjust the take-up cords at bottom bar if needed.

SOMFY MEXICO, S.A. De C.V.

Calle 3 No. 47, Loc. E-5
Fracc Ind. Alce Blanco
Nau., Edo. de Mex
C.P. 53370

SOMFY SYSTEMS, INC.

1-800-437-6639
47 Commerce Drive
Cranbury, NJ 08512

SOMFY CANADA

6315 Shawson Drive, Unit #1
Mississauga, Ontario L5T1J2

SOMFY SYSTEMS, INC. reserves the right to update, change or improve this product without further notice.