

DECORATOR COMFORT CONTROL (DCC)

DESCRIPTION

The Decorator Comfort Control (DCC) enables a window treatment to provide shading from the sun automatically and conveniently. The DCC sun sensor continually monitors sun intensity, triggering the control unit and motor to raise or lower the shades as needed.

The Decorator Comfort Control features advanced circuitry that assures factory preset accuracy and proven reliability. It helps protect furniture and carpeting from fading and saves on heating and air conditioning costs. With its sleek design, the DCC will complement any home decor. Combine this with the capability of being linked to SOMFY's Group Control and IGC systems, and you've got an extremely flexible product.



MECHANICAL SPECIFICATIONS

Overall Dimensions: L: 3 1/2 in. W: 2 3/4 in. D: 1 1/3 in.

Operating Temperature Range: -20° C to 50° C (-5° F to 120° F)

Fits in most 2 gang electrical boxes

ELECTRICAL SPECIFICATIONS

Voltage Ratings:

Single Motor:

INPUT: 120 VAC +/- 10% 50/60 Hz.

OUTPUT: 120 VAC 5A 1/4 HP

IGC/GCS:

INPUT: 12 - 15 VDC 150mA (Supplied by IGC or GCS)

OUTPUT: 12 - 15 VDC 150mA (Open Collector)

Approvals:

The DCC Single Motor Control is approved per UL508 for industrial controls (UL, cUL)

Complies with the National Electrical Code (NEC) Standard

INSTALLATION PROCEDURES

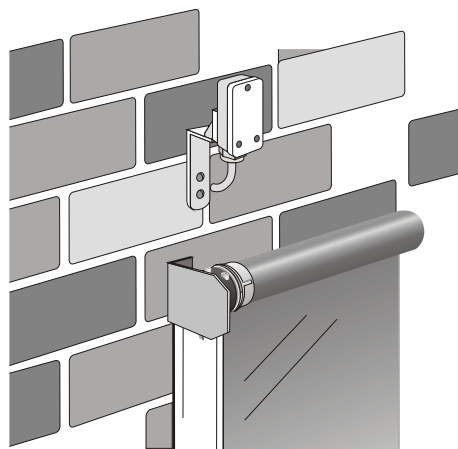

1. Make sure the sun sensor is mounted outside, facing the sun and is not shaded by trees or other building structures. It should be mounted as high as possible, no more than 100 feet from the Decorator Comfort Control. The detection angle is up to 100 degrees wide from the center of the sensor face. Connect the sensor wires to the terminal block as shown in the diagram on the next page.
2. For the Single Motor model, connect the motor wires to the DCC as illustrated.
3. For the IGC/GCS II models, using appropriate length modular cable, connect from the IGC/GCS II connector on the Decorator Comfort Control to the Master connector on the IGC or GCS II. Please refer to the IGC or GCS II instructions for further information.

OPERATING PROCEDURES

- Pressing the UP button will move the window covering up. Pressing the DOWN button will lower it when pressed. If a motor does not move in the correct direction, turn off the circuit breaker(s) and reverse the red and black wires at the corresponding motor(s).
- Pressing the STOP button will stop the motor in its present position.
- When the monitored sun intensity is greater than the DCC setting, the DOWN direction will activate after 3.5 minutes. The sun LED will remain on for as long as this condition exists. If the sun intensity is less than the DCC setting, the UP direction will activate after 15 minutes (if the auto LED is illuminated). The sun LED will blink during this time period.
- When the AUTO button is pressed, the AUTO LED will turn on or off depending on its previous status. Manual mode is designated by the LED being off. If the DCC is in manual mode, the sun level has no influence on motor control.
- With the Summer/Winter switch in the SUMMER position (to the left), the Decorator Comfort Control sun functions will operate as outlined above. When the switch is in the WINTER position (to the right) the Decorator Comfort Control sun functions will operate in the opposite directions. Manual operation will cancel automatic function for one full cycle. To reset, press the auto button OFF and ON.

DCC WIRING DIAGRAMS

CAUTION: Before proceeding with the line voltage wiring instructions, the up and down limits of each motor should be set using the SOMFY tester cable (Cat. No. 6020086). Refer to limit switch instructions packaged with each SOMFY motor for more information.

NOTE: When using a GCS II, the sun sensor can be connected to the GCS II instead of the DCC if convenient.

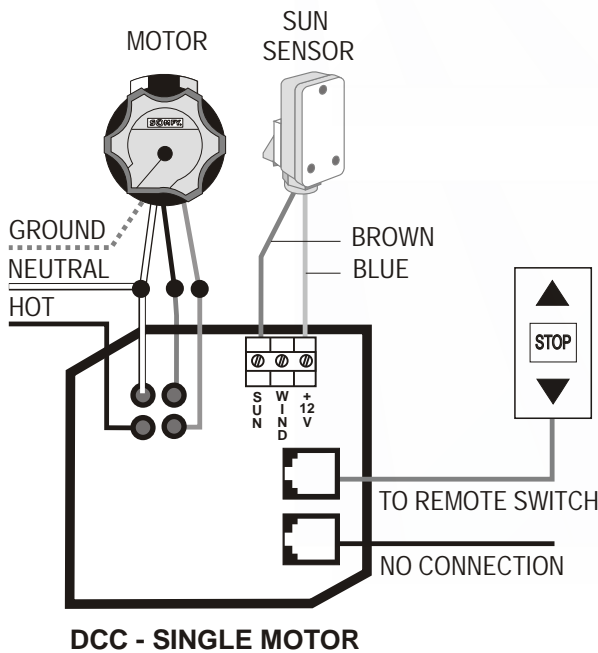

POWER CONNECTIONS COLOR CODE

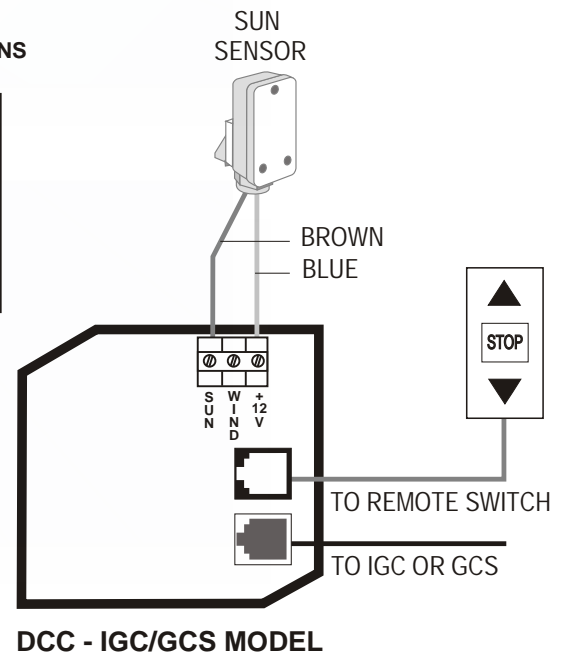
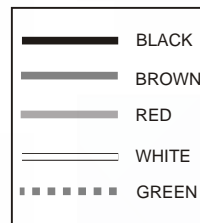

ORDERING INFORMATION

Description	Catalog Number	
DCC - Single Motor	6300901 (White)	6300931 (Ivory)
DCC - IGC	6300897 (White)	6300927 (Ivory)
DCC - GCS II	6300905 (White)	6300935 (Ivory)
OPTIONS:		
Sun Sensor and Bracket	6300415	
Optional Switch	6300908 (White)	6300937 (Ivory)
RTS Radio Receiver	6300450	

EOLIS

Wind Control

DESCRIPTION



The SOMFY Eolis is a single motor control designed for residential use. It includes a wind sensor and low voltage switch. Wind speed is continuously monitored, triggering the control to retract awnings, rolling shutters or exterior screens automatically as needed. This control is packaged in a weatherproof enclosure and includes watertight strain-relief fittings for wires entering the box.

MECHANICAL SPECIFICATIONS

Overall Dimensions: L: 6 in. W: 4 1/4 in. D: 2 1/4 in.

Wind Speed: 12 to 31 mph

ELECTRICAL SPECIFICATIONS

Voltage Ratings:

INPUT: 120 VAC +/- 10% 50/60 Hz.

OUTPUT: 120 VAC 5A 1/4 HP

Approvals: The Eolis is UL508 for industrial controls (UL, cUL)

WIRING DIAGRAM

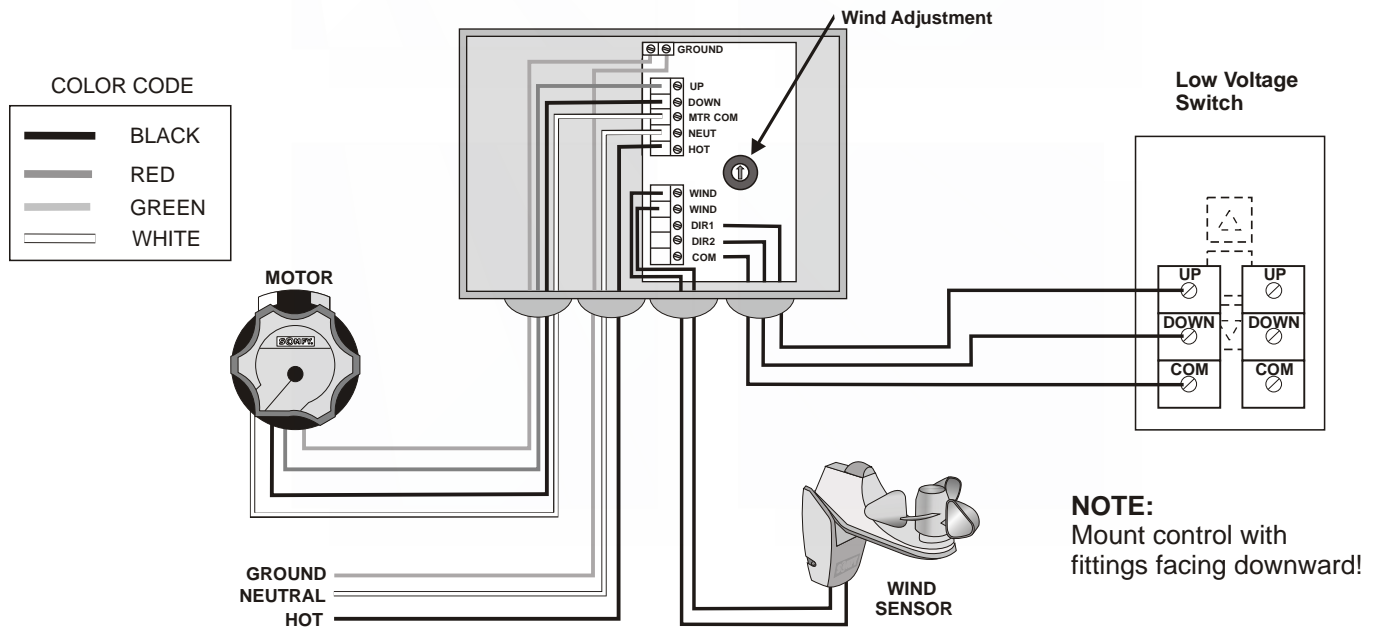

ORDERING INFORMATION

Description	Catalog Number
Eolis Box Kit (control, wind sensor, IGC Switch)	6301021
Eolis Box (control only)	6301027
Eolis Sensor	6150545
IGC Switch w/ Terminals, White	6300040
IGC Switch w/ Terminals, Ivory	6300140

EOLIS RTS RECEIVER

Wind-Remote Control

DESCRIPTION



The SOMFY Eolis RTS Receiver is a single motor control designed for residential use. It includes an integrated radio receiver, wind sensor and low voltage switch inputs. Wind speed is continuously monitored, triggering the control to retract awnings, rolling shutters or exterior screens automatically as needed. Using the single or four-channel Telis Transmitters, it is possible to operate the controls individually or in groups. Two user-defined intermediate positions can be programmed. This new control is packaged in a weatherproof enclosure and includes watertight strain-relief fittings for wires entering the box.

MECHANICAL SPECIFICATIONS

Overall Dimensions: L: 6 in. W: 4 1/4 in. D: 2 1/4 in.

Wind Speed: 12 to 31 mph

Frequency Range (optimal conditions): 65 ft.

ELECTRICAL SPECIFICATIONS

Voltage Ratings:

INPUT:	120 VAC +/- 10%	50/60 Hz.
OUTPUT:	120 VAC	5A 1/4 HP

Approvals:

The Eolis Receiver is UL508 for industrial controls (UL, cUL)
Complies with the National Electrical Code (NEC) and
FCC Standards



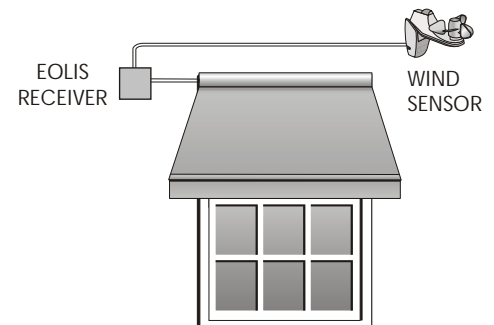
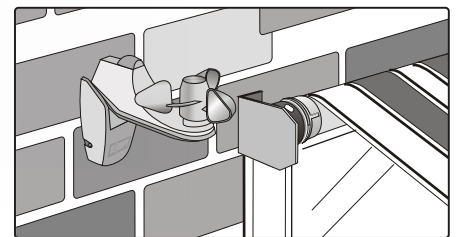

INSTALLATION PROCEDURES

1. The Eolis Receiver should be mounted as close to the motor as possible. If mounted outside, ensure that the connections are facing down to avoid moisture seepage. Avoid mounting the control against any metallic surface, as this may affect radio reception.
2. Connect high and low voltage wires according to the wiring diagram on the next page. It is recommended that the low voltage wiring is done first, for easier access to the terminals. Make sure to use included watertight strain relief fittings to maintain the weatherproofing of the enclosure.
3. The wind sensor should be placed close to the awning or shading system to make sure the wind speed is measured at the product. Guard against installing the wind sensor too close to an obstruction such as a chimney, gutter or the window covering itself, which could block the wind and cause erroneous sensor readings. The sensor should not be more than 100 feet from the control.
4. When using a low voltage switch, it should be located no more than 100 feet from the Eolis Receiver.



WIRING DIAGRAM

COLOR CODE

	BLACK
	RED
	GREEN
	WHITE

CAUTION:

Mount control with fittings facing downward!

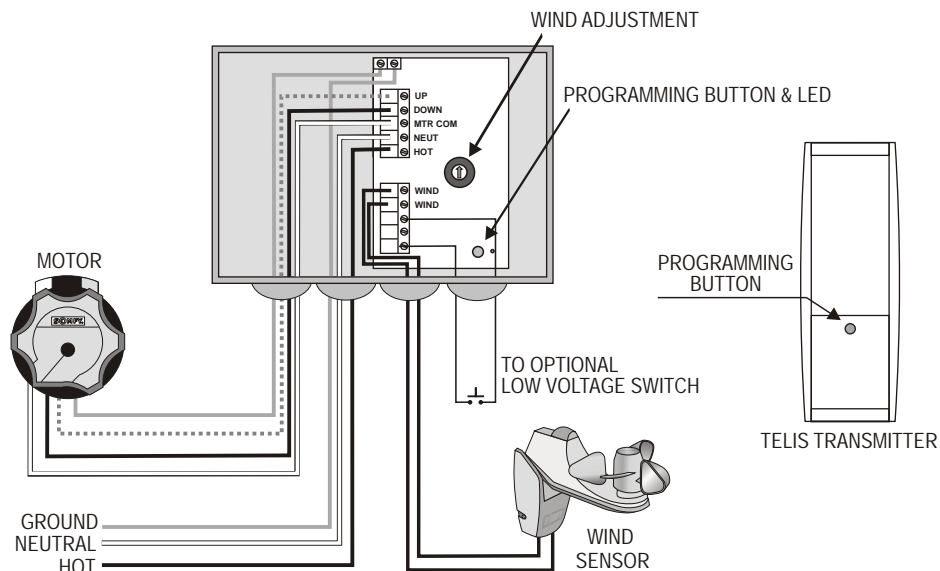

OPERATING INSTRUCTIONS

System Set Up

1. With power off, wire the Eolis Receiver as indicated above. Turn all circuit breakers on (motors should not move).
2. Set the Eolis Receiver into programming mode by pressing the programming button on the receiver until the LED lights solid (about 5 seconds).
3. Press the programming button on the Telis1 or Telis 4 transmitter. Make sure the desired channel is selected on the Telis 4 before programming. The programming LED on the Eolis Receiver will blink indicating the transmitter has been memorized.
4. Operate each motor in the DOWN direction using the radio transmitter. The motorized product should move down or out. If this is incorrect, turn off the circuit breakers and reverse the red and black wires of the motor. **FAILURE TO CORRECT THIS ERROR WILL CAUSE AWNING TO EXTEND DURING WINDY CONDITIONS AND MAY CAUSE SERIOUS DAMAGE.**

Setting The Wind Level

1. To change the wind sensitivity, simply rotate the wind adjustment knob to the desired setting.

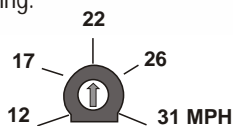

Wind Adjustment Detail

Operating Procedures

TRANSMITTER

1. Pressing the UP button on the Telis transmitter will move the window treatment up or in. The DOWN button will move the exterior screen or awning down or out.
2. To stop the motorized window covering at any time, press the CENTER button on the transmitter.
3. To reach one of the intermediate positions, the awning or exterior screen must first be stopped at the upper or lower limit. Pressing the center button on the transmitter will move the window covering to the desired position.

WIND FUNCTION

4. When the monitored wind speed is greater than the setting, the UP direction will activate after 2 seconds. As long as the wind speed remains high, all other commands will be ignored.
5. When the wind speed drops below the set value, the Eolis Receiver will return to normal operation following a one minute delay.

LOW VOLTAGE SWITCH

6. If desired, a single pole, single throw switch can be connected to the low voltage terminals as indicated above. Each press of the switch will sequence through the directions as follows:

DEPRESS 1	UP DIRECTION
DEPRESS 2	STOP
DEPRESS 3	DOWN DIRECTION
DEPRESS 4	STOP

ORDERING INFORMATION

Description	Catalog Number	Description	Catalog Number
Eolis Receiver Kit (control & wind sensor)	6301022	Telis 1 RTS Transmitter	6301014
Eolis Receiver (control only)	6301028	Telis 4 RTS Transmitter	6301015
Eolis Sensor	6150545	Inteo, Decora RTS 1 Switch	6301033 (White), 6301034 (Ivory)
SPST Momentary Switch	6300080 (White)	Inteo, Decora RTS 4 Switch	6301025 (White), 6301035 (Ivory)
		Chronis RTS Timer	6300383

SOLIRIS RTS RECEIVER

Sun & Wind-Remote Control

DESCRIPTION



The SOMFY Soliris RTS Receiver enables a motorized awning or exterior screen to provide shading from the sun and protection from the wind automatically and conveniently. The Soliris combined sun and wind sensor continually monitors sun intensity and wind speed, triggering the control unit to extend or retract an awning as needed. It includes an integrated radio receiver that makes it possible to operate the controls individually or in groups, using the Telis transmitters. Two user-defined intermediate positions can be programmed. This control is packaged in a weatherproof enclosure and includes watertight strain-relief fittings for wires entering the box.

MECHANICAL SPECIFICATIONS

Overall Dimensions: L: 6 in. W: 4 1/4 in. D: 2 1/4 in.

Frequency Range (Optimal Conditions): 65 ft.

Wind Speed: 12 to 31 mph

ELECTRICAL SPECIFICATIONS

Voltage Ratings:

INPUT:	120 VAC +/- 10%	50/60 Hz
OUTPUT:	120 VAC 5A	1/4 HP

Approvals: The Soliris Receiver is UL508 for industrial controls (UL, cUL)

Complies with the National Electrical Code (NEC) and FCC Standards

INSTALLATION PROCEDURES

1. The Soliris Receiver should be mounted as close to the motor as possible. If mounted outside, ensure that the connections are facing down to avoid rain seepage. Avoid mounting the control against any metallic surface, as this may affect radio reception.
2. Connect high and low voltage wires according to the wiring diagram on the next page. The low voltage wiring should be done first, to gain easier access to the terminals. Make sure to use included watertight strain relief fittings to maintain the weatherproofing of the enclosure.
3. The combined sensor should be placed close to the awning or shading system to make sure the wind speed is measured at the product. Guard against installing the wind sensor too close to an obstruction such as a chimney, gutter or the window covering itself, which could block the wind and cause erroneous sensor readings. The sensor should also not be mounted in the shade or be obstructed by trees, to ensure accurate sunlight readings. The sensor should not be more than 100 feet from the control.
4. When using a low voltage switch, it should be located no more than 100 feet from the Soliris Receiver.

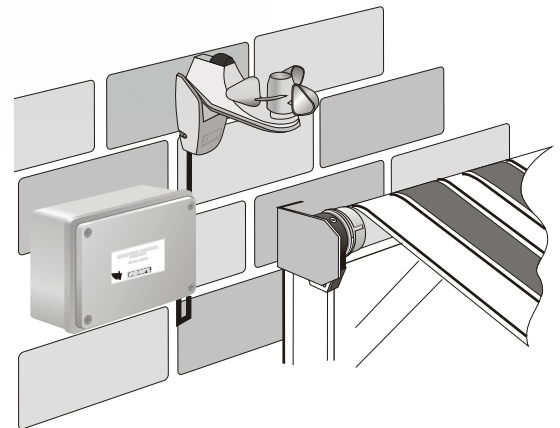

WIRING DIAGRAM

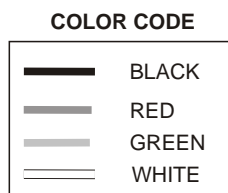

CAUTION:
Mount control with fittings facing downward!

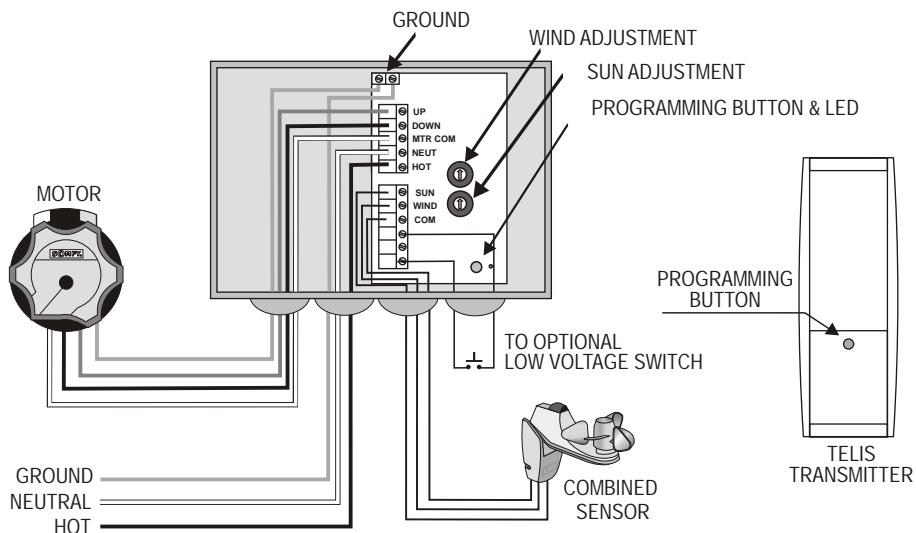

OPERATING INSTRUCTIONS

System Set Up

1. With power off, wire the Soliris Receiver as indicated. Turn all circuit breakers on (motors should not move).
2. Set the Soliris Receiver into programming mode by pressing the programming button until the LED lights solid (about 5 seconds). Press the programming button on the Telis 1, Telis 4 or Telis Soliris transmitter. The programming LED will blink indicating the transmitter has been memorized.
3. Operate each motor in the DOWN direction using the radio transmitter. The motorized product should move down or out. If this is incorrect, turn off the circuit breakers and reverse the red and black wires of the motor. **FAILURE TO CORRECT THIS ERROR WILL CAUSE DAMAGE TO AWNING BY EXTENDING IT DURING WINDY CONDITIONS.**

Setting The Wind Level

1. To change the wind sensitivity, simply rotate the wind adjustment knob to the desired setting. All time delays are reduced at the Installation Mode setting.

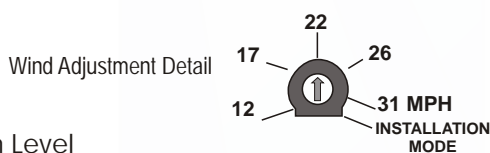

Setting The Sun Level

1. To change the sun sensitivity, simply rotate the sun adjustment knob to the desired setting. Be sure not to keep the sun level at the minimum setting.

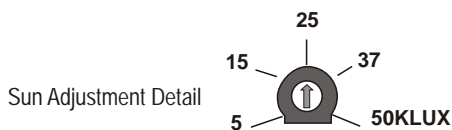

Operating Procedures

TRANSMITTER

1. Pressing the UP button on the Telis transmitter will move the exterior window covering up or in. The DOWN button will move it down or out.
2. To stop the motorized product at any time, press the CENTER button on the transmitter.
3. Pressing the SUN/WIND button on the Telis Soliris Transmitter will toggle between wind only and sun and wind operation. When the wind only function is selected, the Soliris Receiver will not activate according to the sun levels.

SUN FUNCTION

4. When the measured sun intensity is greater than the set level, a DOWN command is given.
5. When the sun intensity falls below the set level, the awning or exterior screen will retract automatically after a 20 minute delay.

WIND FUNCTION

6. When the monitored wind speed is greater than the setting, the UP direction will activate after 2 seconds. As long as the wind speed remains high, all other commands will be ignored.
7. When the wind speed drops below the set value, the Soliris Receiver will extend the awning automatically after a 12 minute delay. However, a manual command can be given with the radio transmitter after only one minute.

LOW VOLTAGE SWITCH

8. An optional single pole, single throw switch can be connected to the low voltage terminals. Each press of the switch will sequence through the directions as follows:

- | | |
|-----------|----------------|
| DEPRESS 1 | UP DIRECTION |
| DEPRESS 2 | STOP |
| DEPRESS 3 | DOWN DIRECTION |
| DEPRESS 4 | STOP |

ORDERING INFORMATION

Description	Catalog Number	Description	Catalog Number
Soliris Receiver Kit (control & combined sensor)	6301024	Telis 1 RTS Transmitter	6301014
Soliris Receiver (control only)	6301029	Telis 4 RTS Transmitter	6301015
Soliris Sensor	6150518	Inteo, Decora RTS 1 Switch	6301033 (White), 6301034 (Ivory)
Telis Soliris Transmitter	6301017	Inteo, Decora RTS 4 Switch	6301025 (White), 6301035 (Ivory)
SPST Momentary Switch	6300080 (White)	Chronis RTS Timer	6300383

TELIS SOLIRIS RTS TRANSMITTER

DESCRIPTION

The Telis Soliris Transmitter is a single channel hand-held transmitter compatible with the Soliris Receiver, Altus motor and Soliris RTS Sensor. It will operate window coverings at a distance as well as switch between Wind-Only or Sun & Wind Modes.



MECHANICAL SPECIFICATIONS

Overall Dimensions: L: 4 $\frac{3}{4}$ in. W: 1 $\frac{3}{4}$ in. D: $\frac{3}{4}$ in.

Operating Temperature: 41°F to 104°F

Frequency Range (optimal conditions): 65 ft.

ELECTRICAL SPECIFICATIONS

Power: 3V Lithium battery, Cr2430

Frequency: 433.42 Mhz

GENERAL OPERATING INSTRUCTIONS

NOTE: Please Consult Altus Motor, Soliris Sensor RTS or Soliris Receiver Instructions for Specific Product Details.

1. Place the Altus Motor or Soliris Receiver in Programming Mode as described in the Operating Instructions.
2. Press the programming button on the back of the Telis Soliris to program it into the memory of the Altus Motor or Soliris Receiver.
3. Pressing the UP button will raise the window covering, while pressing the DOWN button will lower it. To stop the window covering, simply press the STOP button.
4. Pressing the Mode Selector button will switch between Wind-Only and Sun & Wind Modes. The corresponding LED will light to indicate the mode selected.

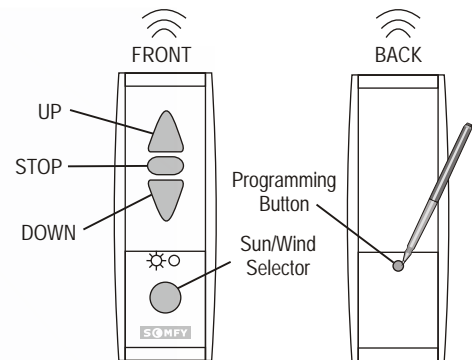

ORDERING INFORMATION

Description	Catalog Number
Telis Soliris RTS Transmitter	6301017
Telis Soliris RTS Patio Transmitter	6301116
Telis Soliris Silk RTS Transmitter	6301117

Telis Soliris
Patio
Transmitter



SOLIRIS 24V & EOLIS 24V RTS SENSOR

DESCRIPTION

The SOMFY Soliris RTS and Eolis RTS sensors are 24V radio sensors compatible with the Altus and LT CMO RTS motors. The Eolis is a wind only, while the Soliris is a combined sun and wind sensor. Sun intensity and wind speed thresholds can be set right on the sensor. The RTS Sensors will command the motor to extend or retract an awning as needed, via radio signal. It comes with a 24V DC transformer to provide power, otherwise additional wiring is not needed.



MECHANICAL SPECIFICATIONS:

Overall Dimensions: L: 9 1/3 in. H: 6 1/3 in.

Frequency Range (optimal conditions): 65 ft.

Cable Lengths: Transformer to Sensor; 30 ft.
Transformer to Power; 6 ft.

ELECTRICAL SPECIFICATIONS:

Power: 24V DC, 20mA (Class 2 transformer)

Frequency: 433.42 Mhz

INSTALLATION

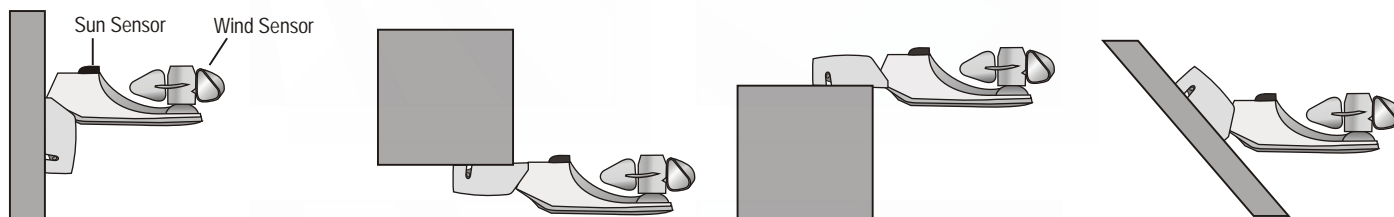

GENERAL OPERATING INSTRUCTIONS

NOTE: Please Consult Motor Instructions for Specific Product Details.

1. Place the Altus or CMO RTS Motor in Programming Mode as described in the Operating Instructions.
2. Press the programming button on the back of the Soliris or Eolis RTS Sensor to program it in the memory of the motor.
3. When the measured wind speed exceeds the threshold set on the RTS Sensor, an UP command is transmitted after 2 seconds. As long as the measured wind speed is greater than the threshold, all other commands will be ignored. Once the measured wind speed falls below the threshold, the exterior window covering can be operated with a Telis transmitter after a 30 second delay. With the Soliris RTS Sensor, the sun will automatically activate the motor after a 12 minute delay.
4. When the measured sun intensity exceeds the threshold set on the Soliris RTS Sensor, a DOWN command is transmitted after 2 minutes. After approximately a 20 minute delay, if the sun intensity falls below the threshold, an UP command will be transmitted.

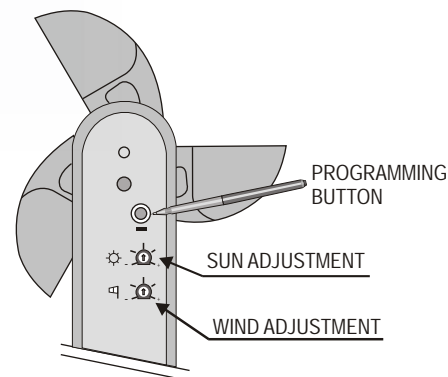

ORDERING INFORMATION

Description	Catalog Number	Description	Catalog Number
Eolis RTS Sensor Kit (Sensor & Transformer)	6301050	Eolis RTS Sensor	6150546
Soliris RTS Sensor Kit	6301051	Soliris RTS Sensor	6150519
		Transformer, 24VDC 20mA	5700000



Remote Controls



Centralis

50

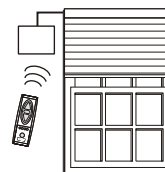

RTS 25 DC Control

52

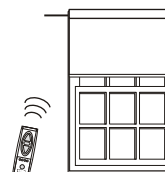

Telis 1 RTS & Telis 4 RTS Transmitters

53

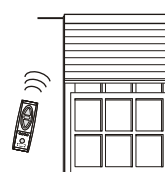

MultiLink

54

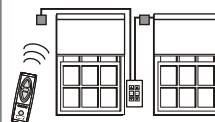

*IRS 300 Infrared Control
for DC Motors*

56

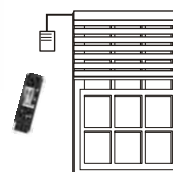

Single Motor Remote

58

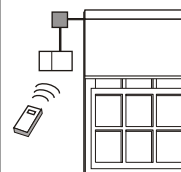

CENTRALIS RECEIVER

Remote Control

DESCRIPTION



The SOMFY Centralis Receiver is a single motor control designed for residential use. It includes an integrated radio receiver, plus input terminals for an optional low voltage switch. Using the Telis Transmitters, it is possible to operate the controls individually or in groups. Two user-defined intermediate positions can be programmed. This control is packaged in a weatherproof enclosure and includes watertight strain-relief fittings for wires entering the box.

MECHANICAL SPECIFICATIONS

Overall Dimensions:

L: 6 in. W: 4 ¹/₄ in. D: 2 ¹/₄ in.

Typical Range (Optimal Conditions): 65 ft.

ELECTRICAL SPECIFICATIONS

Voltage Ratings:

INPUT: 120 VAC +/- 10% 50/60 Hz.

OUTPUT: 120 VAC 5A 1/4 HP

Approvals: The Centralis Receiver is UL508 for industrial controls (UL, cUL)
Complies with the National Electrical Code (NEC) and FCC Standards

INSTALLATION PROCEDURES

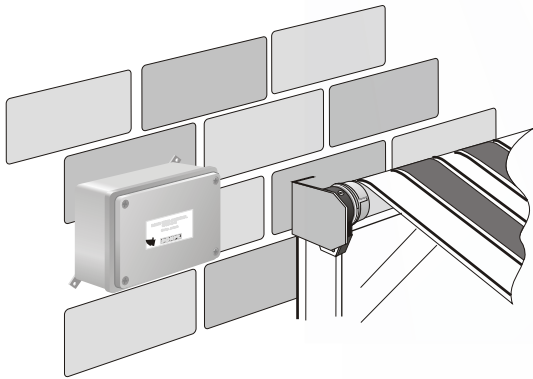





1. The Centralis Receiver should be mounted as close to the motor as possible. If mounted outside, ensure that the connections are facing down to avoid rain seepage. Avoid mounting the control against any metallic surface, as this may affect the radio reception.
2. Connect high and low voltage wires according to the wiring diagram on the next page. It is recommended that the low voltage wiring is done first, for easier access to the terminals. Make sure to use included watertight strain relief fittings to maintain the weatherproofing of the enclosure.
3. When using a low voltage switch, it should be located no more than 100 feet from the Centralis Receiver.

ORDERING INFORMATION

Description	Catalog Number	Description	Catalog Number
Centralis Receiver		Inteo, Decora RTS 1 Switch	6301033 (White), 6301034 (Ivory)
Centralis Plug-In	6301023	Inteo, Decora RTS 4 Switch	6301025 (White), 6301035 (Ivory)
Telis 1 RTS Transmitter	6301032	Chronis RTS Timer	6300383
Telis 4 RTS Transmitter	6301014	Chronis Lite Timer with Sun	6300385
SPST Momentary Switch (White)	6301015	Sensor	
	6300080	and 6' Cord	

WIRING DIAGRAM

COLOR CODE	
	BLACK
	RED
	GREEN
	WHITE

NOTE:
Mount control with fittings
facing downward!

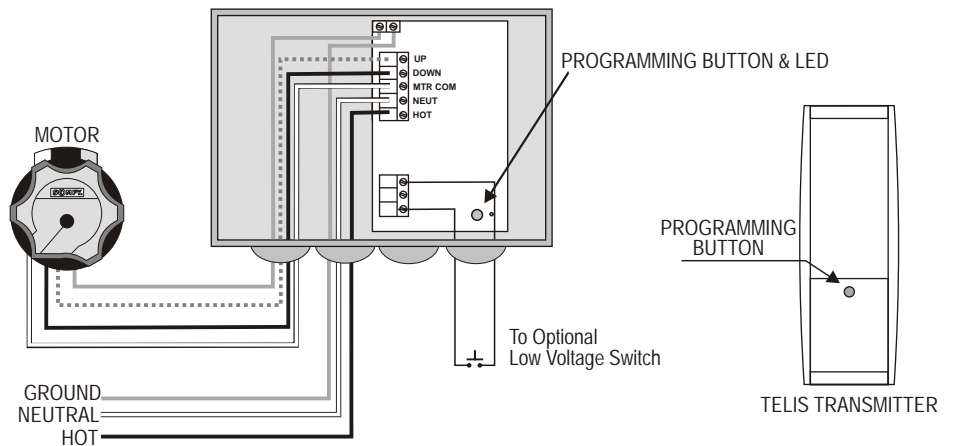

OPERATING INSTRUCTIONS

System Set Up

1. With power off, wire Centralis as indicated above. Turn all circuit breakers on (motors should not move).
2. Set the Centralis Receiver into programming mode by pressing the programming button on the receiver until the LED lights solid (about 5 seconds).
3. Press the programming button on the Telis1 RTS or Telis4 RTS transmitter. Make sure the desired channel is selected on the Telis4 before programming. The programming LED on the Centralis will blink indicating the transmitter has been memorized.
4. Operate each motor in the DOWN direction using the radio transmitter.
5. The motorized window covering should move down or out. If this is incorrect, turn off the circuit breakers and reverse the red and black wires of the motor.

TRANSMITTER

1. Pressing the UP button on the Telis transmitter will move the window covering up or in. The DOWN button will move the treatment down or out.
2. To stop the motorized product at any time, press the CENTER button on the transmitter.
3. To reach one of the intermediate positions, the awning or rolling shutter must first be at the upper or lower limit, and stopped. Pressing the center button on the transmitter will move the window covering to the desired position.

LOW VOLTAGE SWITCH

4. If desired, a single pole, single throw switch can be connected to the low voltage terminals as indicated above. Each press of the switch will sequence through the directions as follows;

DEPRESS 1	UP DIRECTION
DEPRESS 2	STOP
DEPRESS 3	DOWN DIRECTION
DEPRESS 4	STOP

Operating Procedures

PROGRAMMING PROCEDURES

RECORDING THE INTERMEDIATE POSITION FROM THE TOP OF THE WINDOW TREATMENT

- Bring the window covering to its upper limit using the Telis transmitter. Press the DOWN and CENTER buttons simultaneously until the awning begins to move, then release.
- Stop the window covering at the intermediate position desired. Press the CENTER button for 2 seconds to memorize that position.

RECORDING THE INTERMEDIATE POSITION FROM THE BOTTOM OF THE WINDOW TREATMENT

- Bring the motorized product to its lower limit. Press the UP and CENTER buttons simultaneously until the window covering begins to move, then release.
- Stop the window covering at the position desired. Press the CENTER button for 2 seconds to memorize that position.

DELETING AN INTERMEDIATE POSITION

- Briefly press the CENTER button of the Telis transmitter to reach the desired intermediate position.
- Continue to press the CENTER button for 10 seconds until the programming LED on the Centralis Receiver stops blinking. That position is now deleted.

TO ADD A NEW TRANSMITTER TO THE MEMORY OF THE RECEIVER

- Press the programming button, for more than 2 seconds, on a transmitter that is already memorized by the Centralis Receiver to wake up the receiver. The programming LED on the Centralis will light. Press the programming button on the new transmitter to attach it to the Centralis Receiver.

TO REMOVE A TRANSMITTER FROM THE MEMORY OF THE RECEIVER

- Press the programming button on the Centralis Receiver until the LED lights. Quickly press the programming button on the transmitter you want to remove.

TO REMOVE ALL TRANSMITTERS FROM THE MEMORY OF THE RECEIVER (Resetting of the Centralis Receiver)

- Press the programming button of the Centralis Receiver until the LED blinks. This removes ALL memorized transmitters.

TELIS RTS TRANSMITTERS

DESCRIPTION

The Telis RTS Transmitters (single or four channel with group control) are hand-held radio controls compatible with RTS Motors and external RTS receivers such as Centralis or HRC-RF. Each transmitter can operate any number of motors or receivers, while each motor or receiver will memorize up to 12 transmitters. The four channel transmitter can be used for group and individual control of window treatments.



MECHANICAL SPECIFICATIONS

Overall Dimensions: L: 4 ³/₄ in. W: 1 ³/₄ in. D: ³/₄ in.

Operating Temperature: 41°F to 104°F

Typical Range (Optimal Conditions): 65 ft.

ELECTRICAL SPECIFICATIONS

Power: 3V Lithium battery, Cr2430

Frequency: 433.42 Mhz

GENERAL OPERATING INSTRUCTIONS

NOTE: Please Consult RTS Motor or Receiver Instructions for Specific Product Details.

1. Place the RTS Motor or Receiver in Programming Mode as described in the Operating Instructions.
2. Press the programming button on the back of the Telis transmitter to program it in the memory of the RTS Motor or Receiver.
3. Pressing the UP button will raise the window covering, while pressing the DOWN button will lower it. To stop the window covering, simply press the STOP button.
4. Pressing the Channel Selector button on the four channel transmitter will switch between channels 1 through four and the group (or fifth) channel. The corresponding LEDs will light to indicate the channel selected.

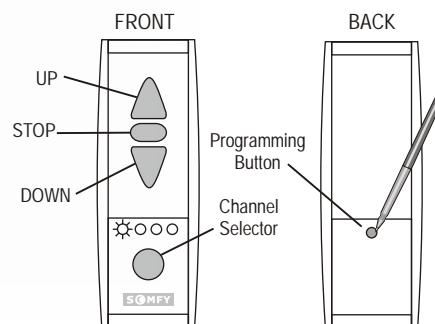

ORDERING INFORMATION

Description	Catalog Number
Telis 1 RTS Transmitter	
Telis 4 RTS Transmitter	6301014
Telis 1 RTS Patio Transmitter	6301015
Telis 4 RTS Patio Transmitter	6301114 6301115

Telis 4 RTS
Patio
Transmitter



MULTILINK™

DESCRIPTION



The MultiLink™ control provides the versatility required by today's motorization specifiers and integrators. This single control can process all the input options commonly used when motorized window coverings are operated autonomously or integrated with other external systems. The MultiLink incorporates dry contact terminals for hard-wired control as well as infrared and radio receivers for remote control.

The MultiLink Snaptrack is an infrared only control that is specifically designed to fit into industry-standard 2.9 in. Snaptrack. This allows for easy panel or cabinet mounting.

MECHANICAL SPECIFICATIONS

Overall Dimensions:

MultiLink:	L: 3 1/8 in.	W: 2 1/8 in.	H: 1 3/8 in.
MultiLink Snaptrack:	L: 3 1/8 in.	W: 2 11/16 in.	H: 7/8 in.

Typical Range:

Radio Remote:	65 ft.
IR Remote:	20 ft.

ELECTRICAL SPECIFICATIONS

Voltage Ratings: INPUT: 115 VAC +/- 10% 50/60 Hz
OUTPUT: 115 VAC 5A 1/4 HP

Approvals: Complies with the National Electrical Code Standards (NEC).
UL, cUL pending

HOME AUTOMATION INTERFACE

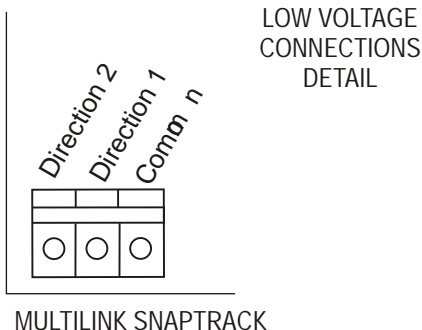
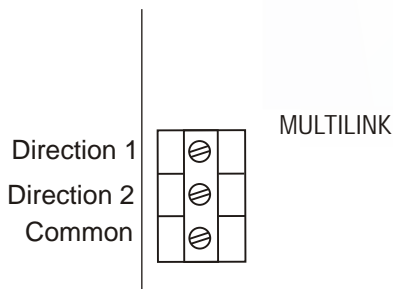

Low voltage terminals are provided on the MultiLink for interfacing to home automation or other third party systems. To activate an Up command, a momentary dry contact (relay) closure is required between the DIRECTION1 input and COMMON. Similarly, to activate a Down command, a contact closure is required between the DIRECTION2 and COMMON terminals. If the window treatment is in motion, a Stop command is given by activating the direction of movement. For example, if the treatment is moving up, activating another UP command within 3 minutes will stop the window treatment. Alternately, to activate a STOP command, a contact closure is required between the DIRECTION1, DIRECTION2 and COMMON terminals.

Modular connectors are provided for connecting to Somfy's Multichannel RS232 interface. When connected to this device, it is possible to operate up to 99 MultiLink controls from a single computer or automation system.

WIRING DIAGRAM

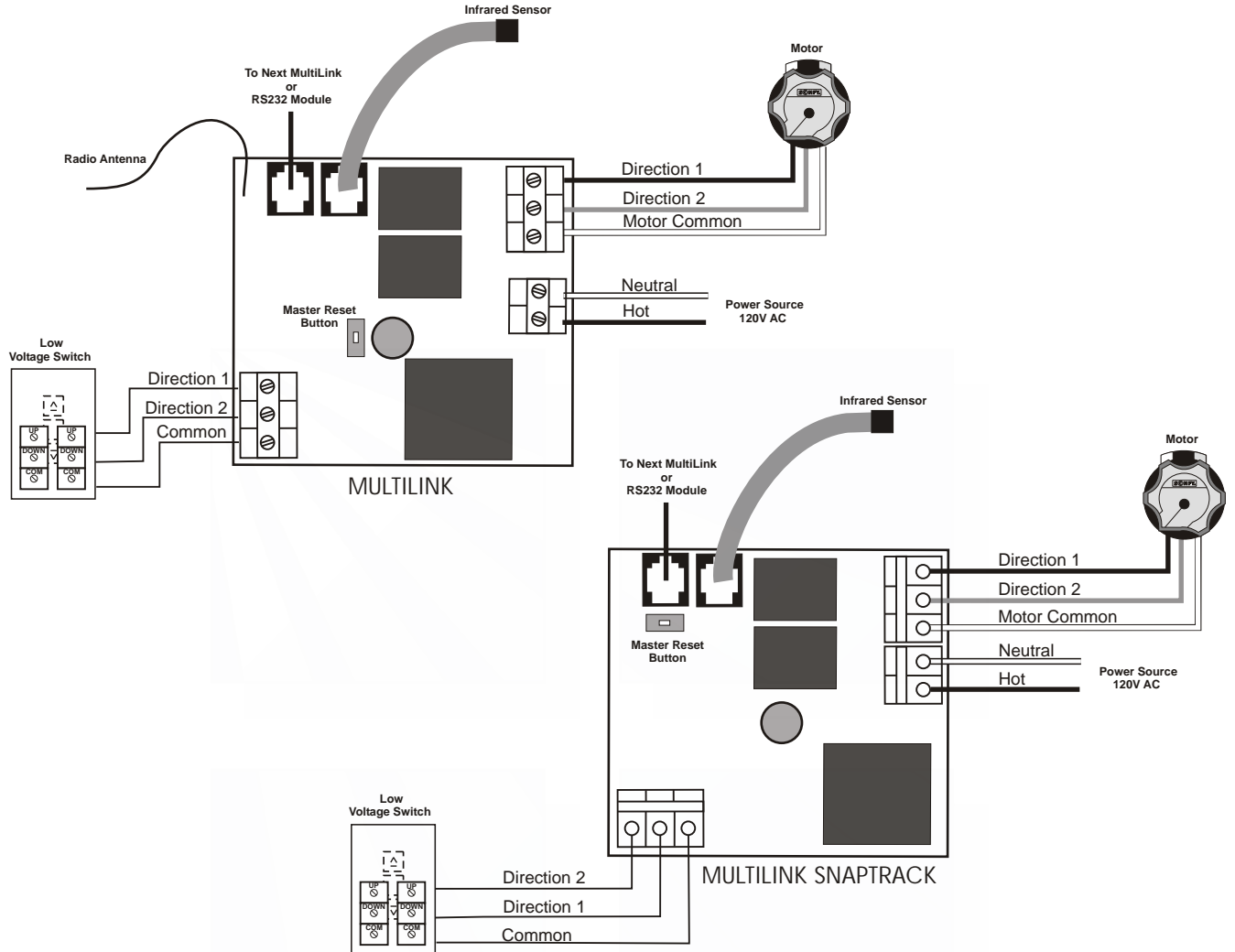

ORDERING INFORMATION

Description	Catalog Number	Description	Catalog Number
MultiLink	6301991	Mini Infrared Sensor	
MultiLink Snaptrack	6301992	24 Channel IR Transmitter	6300023
Single IGC Switch	6300040 (White), 6300140 (Ivory)	MultiChannel RS232 Interface	6300500
Telis 1 RTS Transmitter	6301014	Surface Mount Enclosure	
Telis 4 RTS Transmitter	6301015	Snaptrack (4ft lengths)	6111983
Inteo, Decora RTS 1 Switch	6301033 (White), 6301034 (Ivory)		6110992
Inteo, Decora RTS 4 Switch	6301025 (White), 6301035 (Ivory)		
Chronis RTS Timer	6300383		
Chronis Lite Timer with Sun Sensor and 6' Cord	6300385		

IRS 300

INFRARED CONTROL FOR DC MOTORS

DESCRIPTION

The IRS 300 provides infrared control for SOMFY's Concept 25 and LT28 motors. It is an addressable, multichannel receiver/control with lift and tilt capabilities. In addition, the IRS 300 provides inputs for both individual and master switches. Each individual IRS 300 can operate up to 3 motors as a group, depending on transformer rating.



MECHANICAL SPECIFICATIONS

Overall Dimensions: L: 2 in. W: 3 in. D: 1 1/4 in.

Typical Range (Optimal Conditions): 20 ft.

Voltage Rating: INPUT: 24 VDC
OUTPUT: 24 VDC, 750mA
per motor

Approvals: Complies with the National Electrical Code (NEC)

Standard
CE approved

ELECTRICAL SPECIFICATIONS

RECOMMENDED TRANSFORMERS

MOTOR TYPE	1 MOTOR	2 MOTOR	3 MOTOR
LT28A	5700088	5700091	5700091
LT28B	5700095	5700093	5700093
LV25-B44	5700095	5700093	5700096
LV25-B64	5700095	5700093	5700096
LW25-B83	5700093	5700096	5700096
LT28-H2	5700093	5700096	5700098

TYPICAL APPLICATION

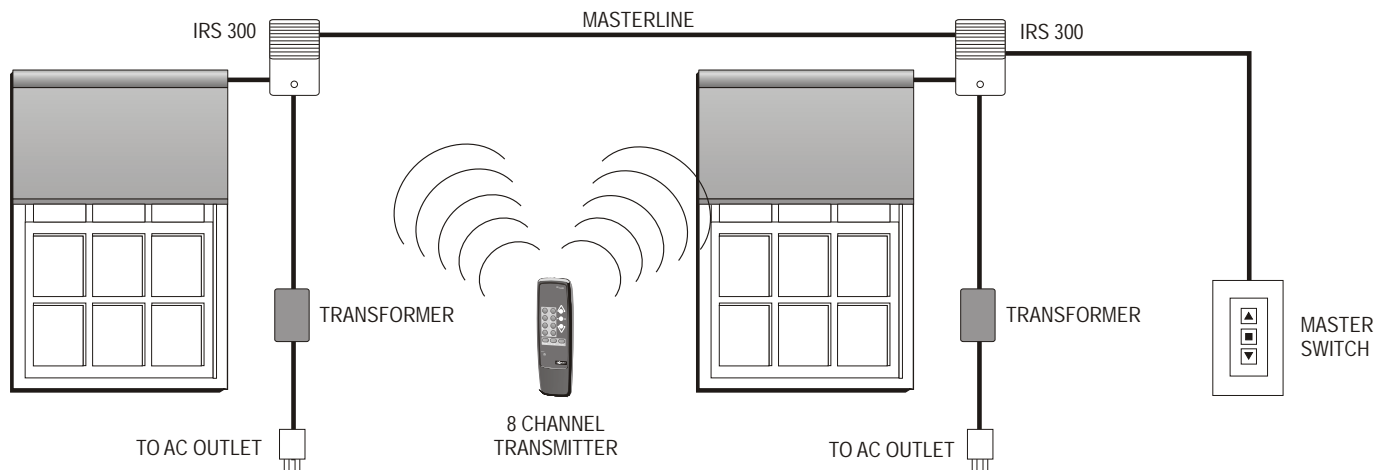

HOME AUTOMATION INTERFACE

The screw terminals on the IRS 300 can be used for interfacing to home automation or other third party systems. To activate a Master Up command, a momentary dry contact (relay) closure is required between the Master Up (▲) input and Common (C). This contact should remain closed for less than 0.5 seconds to raise or lower a shade, or more than 0.5 seconds to tilt a horizontal blind. Similarly, to activate a Master Down command, a contact closure is required between the Master Down (▼) and Common terminals. To activate a STOP command, a contact closure is required between the Master Up, Master Down and Common terminals.

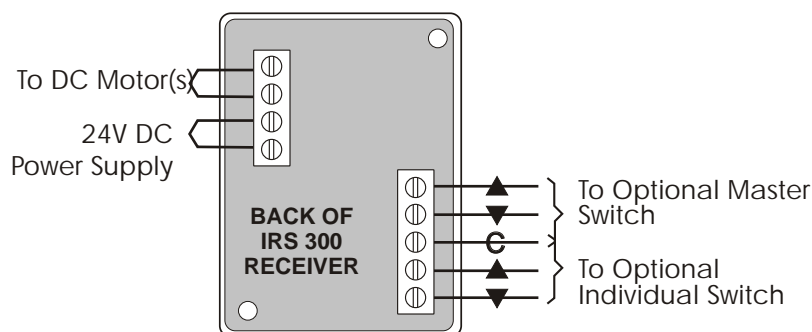

Follow the above timing requirements for the individual input.

PROGRAMMING INSTRUCTIONS

For greater details, please refer to product

SETTING INDIVIDUAL ADDRESSES

- Press and hold the PROGRAM button on the IRT803 Transmitter for at least 5 seconds to enter programming mode. The window covering will respond by moving briefly.
- Press the "1" button on the transmitter, the motor will stop moving. Press the numeric key corresponding to the desired individual address, the control will respond by briefly moving the window covering.
- Proceed with another setting or press the PROGRAM button to exit.

SETTING THE TILT SPEED

- If not already in programming mode, enter programming mode as described above.
- Press the "5" button on the transmitter, the motorized blind will begin to tilt.
- Increase the speed by pressing the UP button on the transmitter, or decrease the speed by pressing the DOWN button.
- Press the "5-8" button on the transmitter to confirm tilt setting, the window covering will begin to move briefly.
- Proceed with another setting or exit programming mode

CANCELLING THE TILT FUNCTION

- Enter programming mode, if not already. Press the "2" key, then the "1" key on the transmitter.
- Press the PROGRAM button to exit.

ORDERING INFORMATION

Description	Catalog Number	Description	Catalog Number
IRS 300	6300989	Transformers	
Transmitters		24 VDC, 600mA	
Single Channel Transmitter		24 VDC, 1A	5700095
8 Channel Transmitter	6300879	24 VDC, 1.2A	5700093
	6300988	24 VDC, 2.5A	5700193
Transformers		24 VDC, 6.5A	5700096
12 VDC, 1A		Switches	5700098
12 VDC, 3A	5700088	Single IGC Switch - White	
12 VDC, 5A	5700091	Single IGC Switch - Ivory	6300040
	5700092		6300140

SINGLE MOTOR REMOTE

DESCRIPTION

Somfy's Remote Control provides motor control from a distance through the use of radio technology. It is compatible with Stanley receivers and transmitters, so insect screens and garage doors can be operated from a single transmitter.

The Digital Remote features an input to lock out the controller. This feature prevents the motor from starting, which may cause damage to an open door or window. It also has dry-contact output capability for operating other devices, such as Somfy's GCS-II.

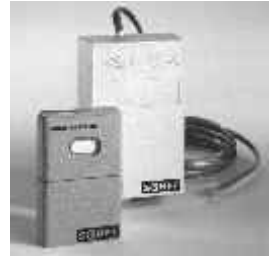

MECHANICAL SPECIFICATIONS

Overall Dimensions: Remote: L: 3 1/2 in. W: 3 1/4 in. D: 2 1/4 in.
Receiver: L: 3 in. W: 4 3/4 in. D: 1 3/8 in.

Typical Range (Optimal Conditions): 75 ft.

ELECTRICAL SPECIFICATIONS

Voltage Ratings:

INPUT:	120 VAC +/- 10%	50/60 Hz		
OUTPUT:	120 VAC	5A	1/4 HP	
	Fuse	5A	115/230 VAC	

Approvals: Complies with the National Electrical Code (NEC) Standard, UR, CSA, and FCC.

WIRING SCHEMATIC

COLOR CODE	
	BLACK
	BROWN
	RED
	WHITE
	GREEN
	YELLOW

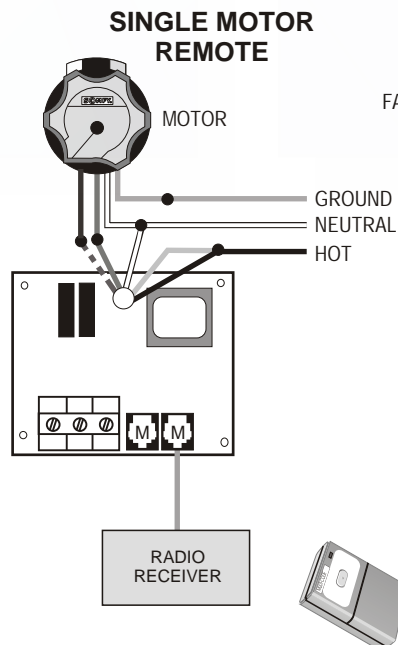

LOW VOLTAGE TERMINAL DETAIL

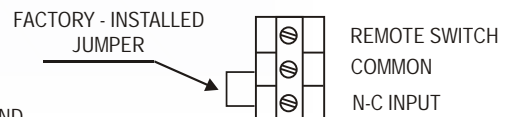

A single-pole, single-throw momentary switch can be connected between the SWITCH and COMMON terminals.

The N-C (normally closed) INPUT terminal is for a normally closed contact connected to a casement window or french door. When the door or window opens, this contact opens and disables the down direction. **DO NOT REMOVE FACTORY INSTALLED JUMPER IF THIS FEATURE IS NOT UTILIZED.**

CAUTION: Before proceeding with the line voltage wiring instructions, the up and down limits of each motor should be set using the SOMFY tester cable (Cat. No. 6020086). Refer to the limit switch instructions packaged with each SOMFY motor for more information.

HOME AUTOMATION INTERFACE

Low voltage terminals are provided for interfacing to home automation or other third party systems. A momentary dry contact (relay) closure is required between the REMOTE SWITCH input and COMMON. This contact should remain closed at least 0.5 seconds, but no more than 1 second. Each closure will sequence through the commands as follows: UP, STOP, DOWN, STOP.

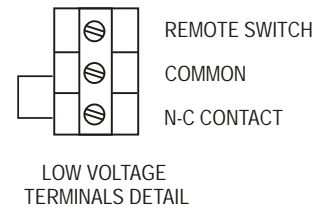

APPLICATIONS

A. Single Motor Remote Control

A single motor can be controlled from a remote switch or radio transmitter. Each press of the switch will sequence through the directions as follows;

- DEPRESS 1 UP DIRECTION
- DEPRESS 2 STOP
- DEPRESS 3 DOWN DIRECTION
- DEPRESS 4 STOP

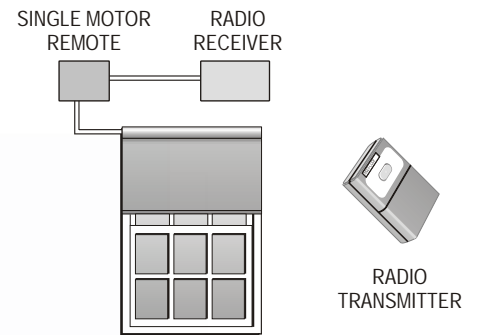

B. Group Control

SOMFY's Group Control System (GCS-II) can be controlled by radio remote by connecting the Single Motor Remote Control to the Low Voltage Switch Connector on the GCS-II. This will provide group only remote control of up to four motors.

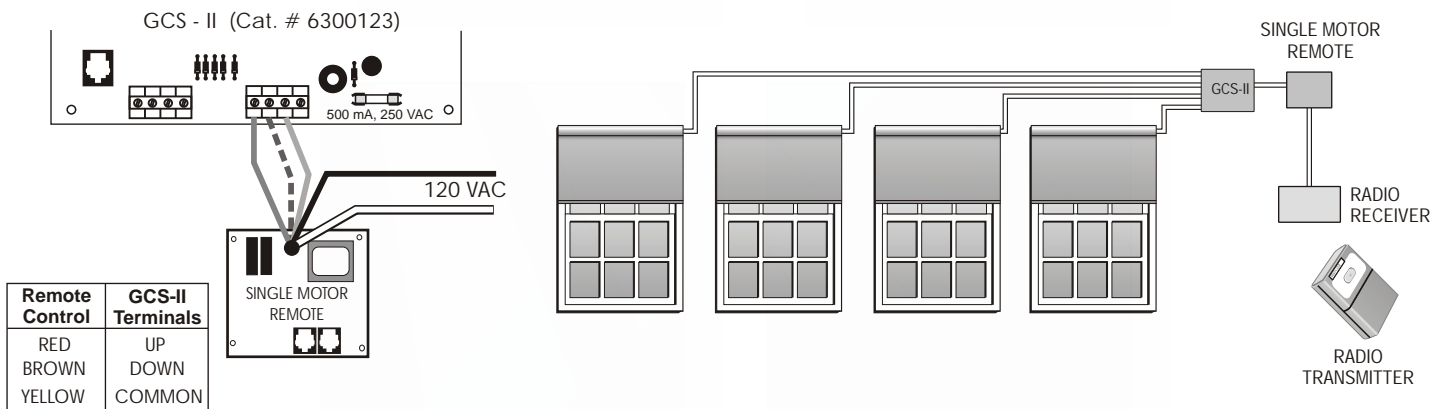









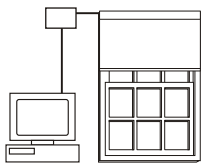

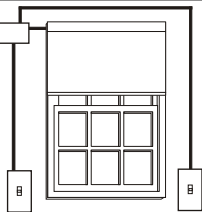

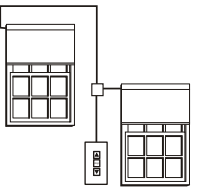
ORDERING INFORMATION

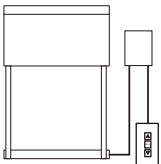
Description	Catalog Number	Description	Catalog Number
Standard Remote Control Remote Controller 115 VAC (Control Only)	6300690	Accessories	
Single Motor Remote Control Kit (Control, Receiver, Transmitter)	6300696	Indoor Digital Keypad	6300739
Receivers/Transmitters		Outdoor Digital Keypad	6300740
Plug-in Single Channel Radio Receiver	6300703	SPST Momentary Switch	6300080
Single Channel Transmitter	6300508	Momentary Outdoor Key Switch (FM, SM)	6120622, 6120212
	6300507	2 Gang Electrical Box	5670323
Two Channel Transmitter	6300509		

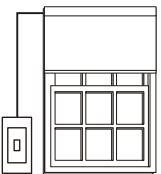

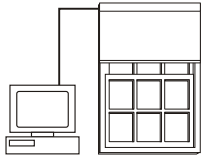
Accessories and Special Applications

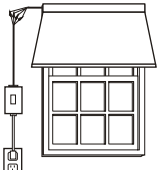
	<p><i>RS 232 Interface</i> <i>Automation Interfaces</i></p>	<p>62 64</p>	
	<p><i>Isolation Control</i></p>	<p>65</p>	
	<p><i>Synchronization Control</i></p>	<p>66</p>	
	<p><i>Fabric Tension System</i></p>	<p>68</p>	
	<p><i>LT28 Stall Sensor</i></p>	<p>69</p>	
	<p><i>ILT Controls</i> <i>LON Controls</i></p>	<p>70 72</p>	
	<p><i>Accessories</i></p>	<p>74</p>	

RS232 INTERFACES



Single Channel Module



Multi Channel Module

DESCRIPTION

SOMFY offers two RS232 Interfaces that translates RS232 protocol for use with SOMFY controls. These units can connect to any PC, home automation or lighting system. The single channel device is addressable and connects to one SOMFY control such as an IGC. One RS232 module is required for each motor or group. The MultiChannel RS232 interface translates RS232 protocol into Somfy infrared code. It is compatible with Somfy's DC5, MultiLink and SnapTrack controls and can operate up to 99 such devices through software. A Graphic User Interface (GUI) is available from Somfy Systems, please contact a sales representative for more information.

MECHANICAL SPECIFICATIONS

Overall Dimensions:	SINGLE CHANNEL:	L: 1 ³ / ₄ in.	W: 3 in.		
	MULTI CHANNEL:	L: 5 ³ / ₈ in.	W: 3 ³ / ₈ in.	H: 1 ¹ / ₂ in.	

ELECTRICAL SPECIFICATIONS

SINGLE CHANNEL: Input Voltage: 12V DC, 150mA (supplied by IGC or MCIR)
Output Voltage: 12V DC, 150mA, open collector

MULTICHANNEL: Input Voltage: 9v DC, 200mA

OPERATING SPECIFICATIONS

Settings: SINGLE CHANNEL: 9600 Baud, 8 Data Bits, 1 Stop Bit, No Parity
MULTI CHANNEL: 1200 Baud, 8 Data Bits, 1 Stop Bit, No Parity

The SOMFY protocol is available upon request.

CONNECTION DIAGRAMS

Single Channel Module

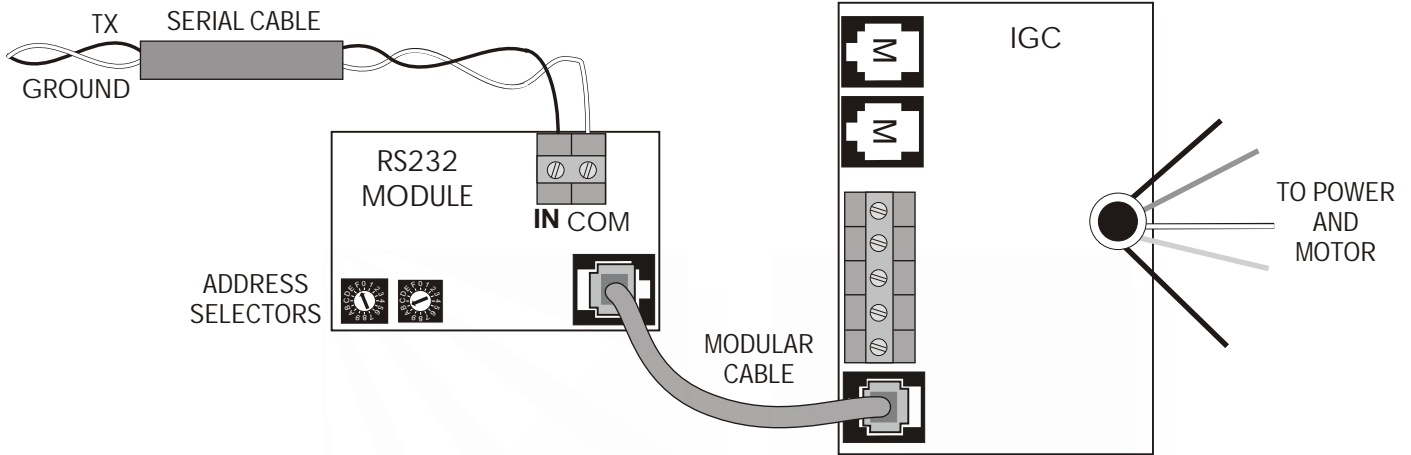

Multi Channel Module

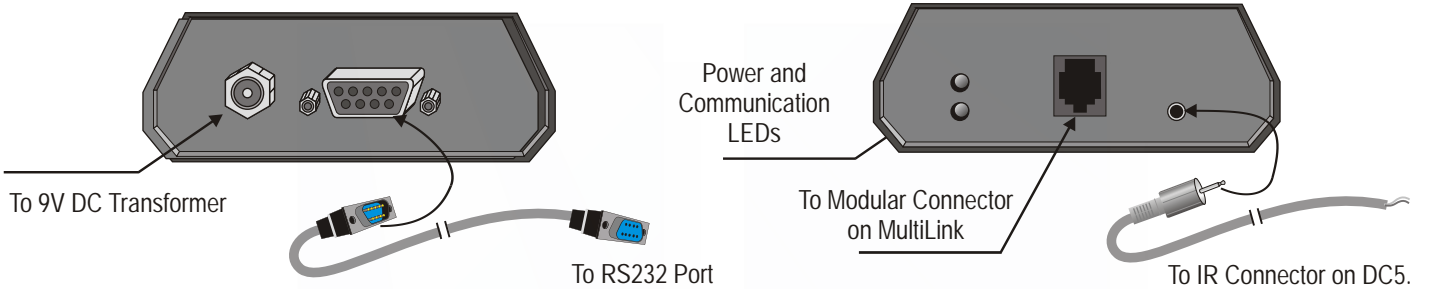

ORDERING INFORMATION

Description	Catalog Number
Single Channel RS232	6300232
Multi Channel RS232	6301232

DRY CONTACT to RTS INTERFACE

DESCRIPTION

These devices were especially designed to allow RTS motors and controls to be more easily operated by third party automation systems. They accept dry-contact relay inputs and transmit RTS radio signals. There are two models, single and five channel. The five channel model also offers RS232 and Infrared inputs.

MECHANICAL SPECIFICATIONS

Overall Dimensions:

Single Channel: L: 6 in. W: 4 1/4 in. D: 2 1/4 in.
Five Channel: L: 5 3/8 in. W: 5 in. D: 1 3/4 in.

ELECTRICAL SPECIFICATIONS

Power: Single Channel: 3v Lithium battery
Five Channel: 9V DC, 200mA

Frequency: 433.42 Mhz

OPERATING INSTRUCTIONS

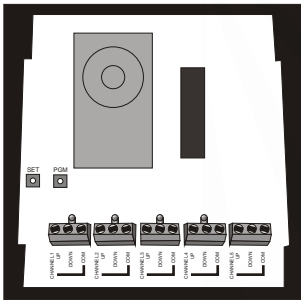

1. Place the RTS Motor in Programming Mode as described in the individual product operating instructions.
2. Select the channel to be memorized by pressing the SET button on the Control Board until the corresponding LED blinks. Briefly press the programming (PGM) button (1 sec. max). Repeat for each channel or product to be memorized. NOTE: All four LEDs blinking indicates Channel 5.
3. Wire dry-contact relay outputs to the indicated terminals at the bottom of the Interface Control box.
4. To activate an UP command, a minimum 0.5 second closure is required between the UP and COM terminals. The top LED on the top of the control box will blink to indicate signal is sent. To activate a DOWN command, a minimum 0.5 second closure is required between the DOWN and COM terminals. To activate a STOP command, a closure is required between all three terminals.
5. Connect the Infrared sensor to the connector provided on the control board. The Interface is compatible with the Somfy Single Channel and Eight Channel transmitters.
6. The 9 pin connector is used to connect to an RS232 serial port. See product instructions for details on protocol.

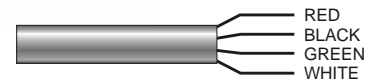
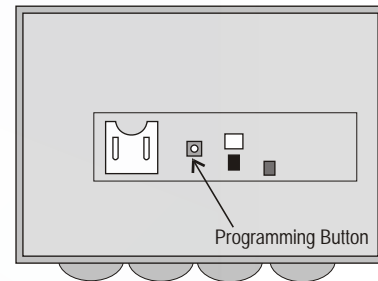

1. Place the RTS Motor in Programming Mode as described in the individual product operating instructions.
2. Press the programming button on the RTS Interface to program it in the memory of the RTS Motor.
3. To activate an UP command, a momentary contact (relay) closure is required between the WHITE and GREEN wires.
4. To activate a DOWN command, a contact closure is required between the BLACK and GREEN wires.
5. To activate a STOP command or Intermediate Position, a contact closure is required between the RED and GREEN wires.

ORDERING INFORMATION

Description	Catalog Number
Single Channel Dry-Contact Input	6300454
Multi Channel Dry-Contact/IR/RS232 Input	6300554
Single Channel Transmitter	6300879
Eight Channel Transmitter	6300989
Infrared Sensor	6300022

ISOLATION CONTROL

DESCRIPTION



The Somfy Isolation Control should be used whenever a motor is operated by two or more switches. The control will keep the switches isolated and prevent both UP and DOWN directions from being activated simultaneously, thus protecting the motor. It can also be used in prewired installations where motors are wired in parallel. Using one Isolation control per motor, several motors can be operated by a single switch. The control should only be used with Momentary Contact switches and 120V AC rated motors.

Catalog No. 6300105

MECHANICAL SPECIFICATIONS

Overall Dimensions: L: $1 \frac{7}{8}$ in. W: $1 \frac{3}{8}$ in. H: $\frac{5}{8}$ in.

ELECTRICAL SPECIFICATIONS

Input:	120 VAC +/- 10%	50/60 Hz.
Output:	120 VAC 5A	1/4 HP

APPLICATION

One Motor, 2 Switches

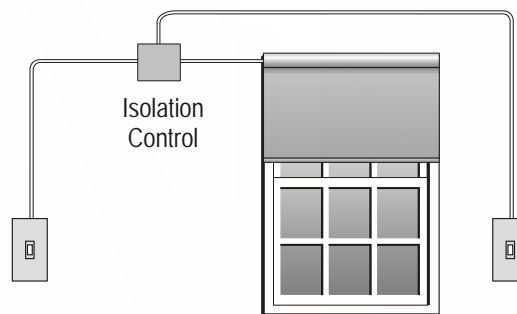

Several Motors, 1 Switch

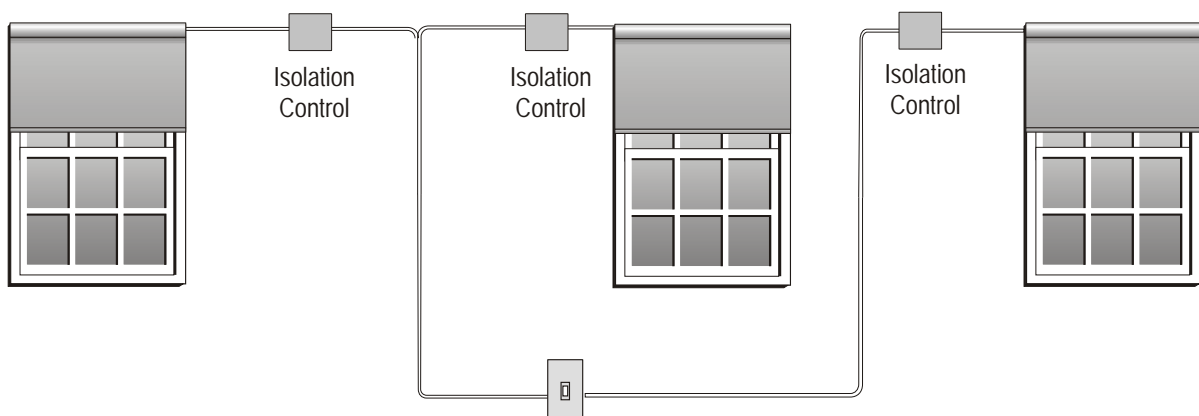

SYNCHRONIZING CONTROL

DESCRIPTION



SOMFY'S Synchronizing Control is designed to control two motors simultaneously. When two SOMFY motors are mounted in a single tube, moving a single window covering, it is important that the motors coincide with each other. The Synchronizing Control actuates and stops both motors at the same time. This helps prevent damage to the tube, motor, and window covering. It is very important not to exceed the load/weight limitations of the mounting hardware such as brackets, fasteners, etc. when synchronizing two SOMFY operators. The Synchronizing Control is available with either maintained (IGC-type) or momentary (GCS-type) outputs.

MECHANICAL SPECIFICATIONS

Overall Dimensions: L: 7 1/4 in. W: 3 1/2 in. D: 1 7/8 in.

Maximum lifting capacity of the Synchronizing system is 300lbs.

Installs in a standard 4 gang masonry electrical box.

ELECTRICAL SPECIFICATIONS

Voltage Ratings:

INPUT: 120VAC +/- 10% 50/60 Hz

OUTPUT: 120VAC 10A (5A/ motor) 1/4 HP
Fuses 3 x 5A

Approvals: Complies with the National Electrical Code (NEC) standard.
UR and cUR approved

ORDERING INFORMATION

Description	Catalog Number
Synchronizing Control (Maintained Output)	6300889
Synchronizing Control (Momentary Output)	6300886
Synchronizing Control - 220V (Maintained Output)	6300689
Synchronizing Control - 220V (Momentary Output)	6300686
Decorator Switch (Modular Plug)	6300908 (White), 6300937 (Ivory)
Decorator Switch (Terminals)	6300040 (White), 6300140 (Ivory)

WIRING DIAGRAM

NOTE: READ INSTRUCTIONS COMPLETELY BEFORE BEGINNING INSTALLATION.

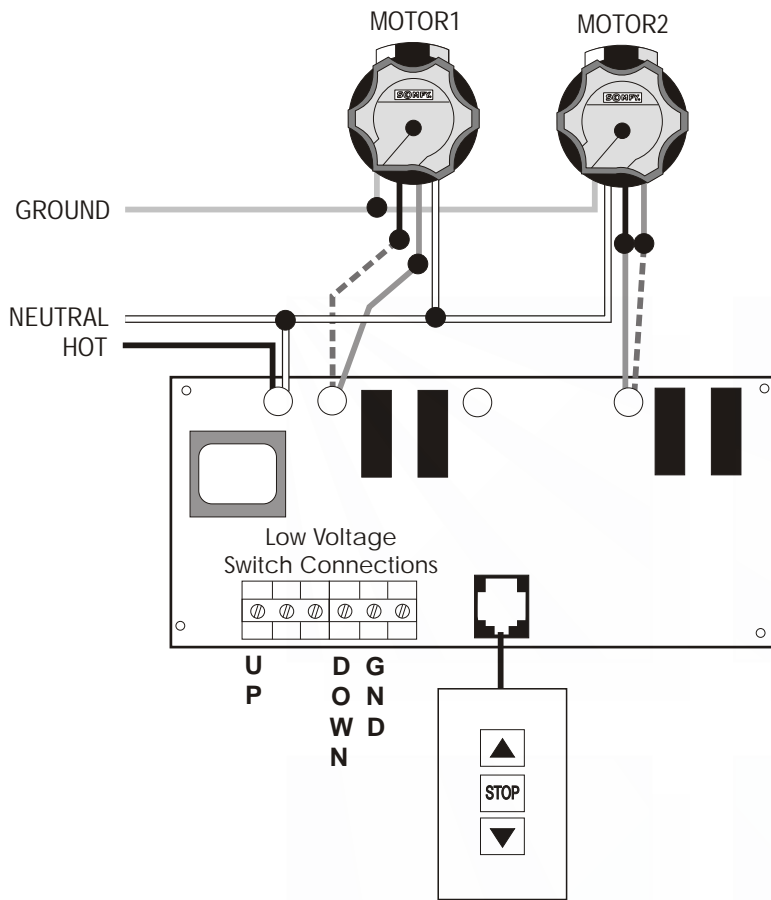

COLOR CODE

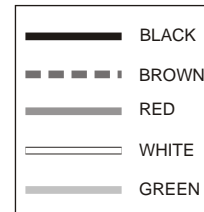

POWER	MOTOR1	MOTOR2	SYNCHRO
BLACK			BLACK
WHITE	WHITE	WHITE	WHITE
GREEN	GREEN	GREEN	GREEN
	RED	BLACK	RED
	BLACK	RED	BROWN

CAUTION: Before proceeding with the line voltage wiring instructions, the up and down limits of each motor should be set using the SOMFY tester cable (Cat. No. 6020086). Refer to the limit switch instructions packaged with each SOMFY motor for more information.

HOME AUTOMATION INTERFACE

Low voltage terminals are provided on the Synchronizing Control for interfacing to home automation or other third party systems.

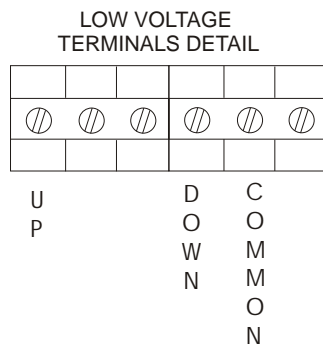

MAINTAINED OUTPUT MODEL:

To activate an UP command, a momentary dry contact (relay) closure is required between the UP input and COMMON. This contact should remain closed at least 0.5 seconds. Similarly, to activate a DOWN command, a contact closure is required between the DOWN and COMMON terminals. To activate a STOP command, a contact closure is required between the UP, DOWN and COMMON terminals.

MOMENTARY OUTPUT MODEL:

To activate an UP command, a maintained dry contact (relay) closure is required between the UP input and COMMON. This contact should remain closed for approximately 3 minutes to ensure full travel of the window covering. Similarly, to activate a DOWN command, a contact closure is required between the DOWN and COMMON terminals. The window covering will stop when the contact closure is released.

FABRIC TENSION SYSTEM CONTROL (FTS)

DESCRIPTION

The FTS is a specialized system designed for the solar protection market where horizontal or inclined type shading is required. The system consists of two specific motors, an electronic control unit and a switch. The control operates each motor independently and maintains a desirable dynamic (moving) tension as well as final tension in the system, eliminating fabric sag while the fabric is both moving and standing. Adjustments to both dynamic and final tension can be made through the electronic control.



For more complete information, refer to SOMFY's FTS instructions. SOMFY's motor and control warranties are based on strict adherence to these instructions.

MECHANICAL SPECIFICATIONS

Overall Dimensions: L: 8 in. W: 10 in. D: 4 in.

Operating temperature range: 0° C to 40° C

ELECTRICAL SPECIFICATIONS

Voltage Rating: INPUT: Line Voltage: 115 VAC +/- 10%
Low Voltage: 5 VDC 0.3 A

OUTPUT: 115 VAC 5A (each motor)
Fuse: 10A

Approvals: Complies with the National Electrical Code (NEC) Standard. UL approval pending.

TYPICAL APPLICATION

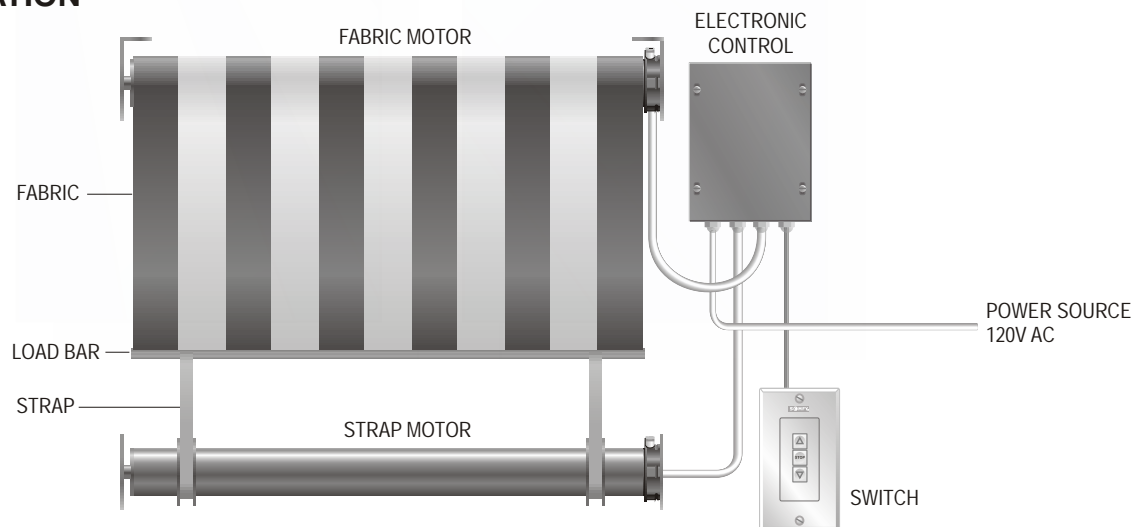

ORDERING INFORMATION

Description	Catalog Number
FTS Control	6300291
Single IGC Switch	6300040 (White), 6300140 (Ivory)
FTS Tester Cable	6020087

LT28 STALL SENSOR

DESCRIPTION

The Stall Sensor is used with interior window coverings that utilize SOMFY's LT28 DC motor. The sensor will cut power to the motor if the bottom of the window treatment meets the headrail before the motor reaches its limit. This prevents stretching of the fabric and extends motor life. This application is useful with certain fabrics that may change shape over time and thus change the actual upper limit. The stall sensor is not intended to replace the upper limit switch of the motor. NOTE: The LT28 must be modified to work with the Stall Sensor. Please consult the sales staff before ordering.

The stall sensor is available as a stand-alone unit (shown right) with a designer switch or in an enclosure without a switch. With the enclosed Stall Sensor, a user may connect any low voltage switch to the input terminals.



MECHANICAL SPECIFICATIONS

Overall Dimensions:

Stand Alone Unit: L: 2 ³/₄ in. W: 4 ¹/₂ in. D: 1 ¹/₄ in.

Enclosed Unit: L: 3 ¹/₂ in. W: 2 ¹/₄ in. D: 1 ¹/₂ in.

Stand alone unit installs in a standard single gang box.

ELECTRICAL SPECIFICATIONS

Voltage Ratings: INPUT: 12 VDC 2A
OUTPUT: 12 VDC 750mA

Approvals:

Complies with the National Electrical Code Standards (NEC)

OPERATING PROCEDURES

1. Pressing the switch UP or DOWN will move the motor in the appropriate direction. If the motor does not move in the correct direction, turn off the circuit breakers and reverse the motor wires at the terminal block.
2. When the UP direction is activated the LED on back of the switch will light. This indicates the protected direction. When the window covering reaches the headrail, the sensor will deactivate the motor. The LED will remain lit until either STOP or DOWN is activated.
3. Moving the switch to the center position will stop the motor.
4. FOR ENCLOSED UNIT: Basic operation is the same, however the directional commands will depend on the remote system used.

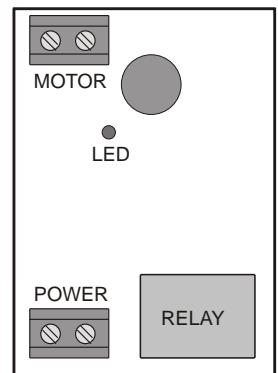

ORDERING INFORMATION

Description	Catalog Number
Decorator Stall Sensor	6300907
Stall Sensor w/Enclosure	6300120

ILT MOTOR CONTROLS

DESCRIPTION

SOMFY's line of ILT motor controls are specifically designed to operate SOMFY's intelligent motors. These controls allow for individual, group or infrared control of one or more ILT motors. Since the ILT motor has on-board intelligence, control interfacing is all done via low voltage wiring. This allows for easy installation and reconfiguration.

COMPONENTS

ILT SWITCH

This decorator, low voltage switch connects directly to the ILT motor using 4 conductor modular cable. The ILT switch can be used to set the motor limits and raise or lower the window covering. The STOP button can be used to set an intermediate position, if desired.

Mechanical Specifications:

Overall Dimensions: L: 4 1/2 in. W: 2 3/4 in. D: 1 1/4 in.
Installs in a standard single gang electrical box.



ILT - IGC

This device allows for combinations of group and individual control of up to four ILT motors. Each switch input is configurable to operate any combination of motor outputs.

Mechanical Specifications:

Overall Dimensions: L: 6 in. W: 8 in. D: 4 in.



INFRARED REMOTE

An infrared sensor will connect directly to an ILT motor using 4 conductor modular cable. SOMFY's Single Channel transmitter can then operate any motors in its range as a group.



4 CONDUCTOR MODULAR SPLITTER

This device has four 4-pin modular connectors on it. It is useful for group control of multiple ILT motors from a single switch or infrared sensor if desired.

Mechanical Specifications:

Overall Dimensions: L: 6 in. W: 8 in. D: 4 in.



TYPICAL APPLICATIONS

Single Motor Remote Control

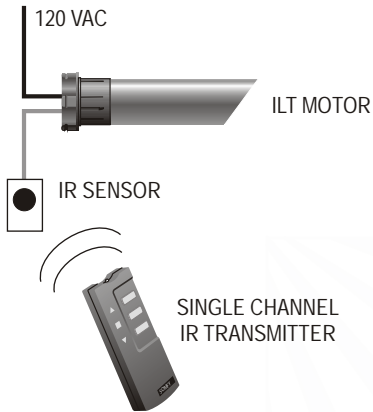

Group Only Control with a Single Switch

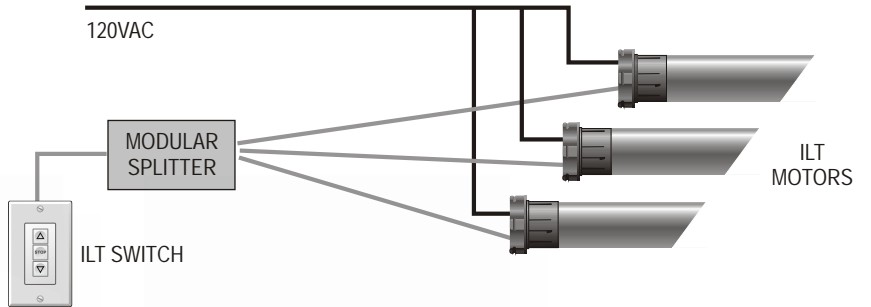

Group and Individual Control

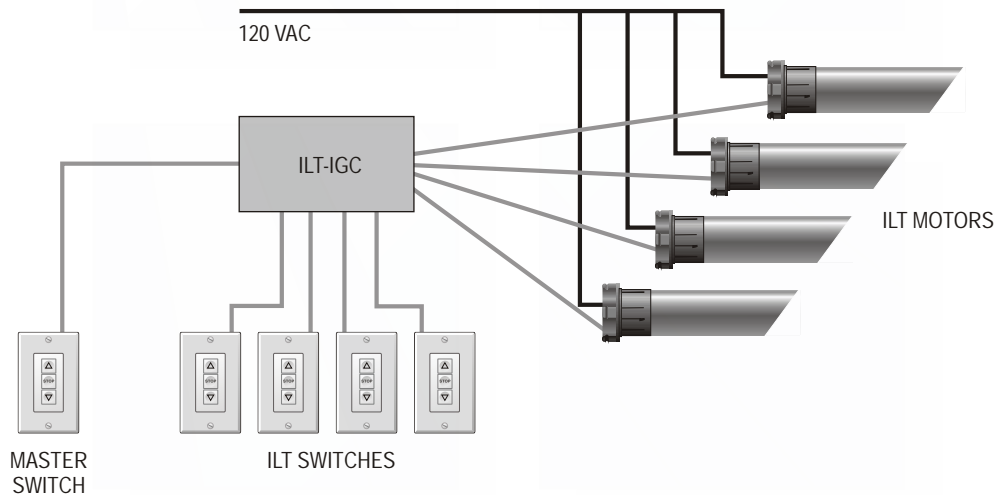

ORDERING INFORMATION

Description	Catalog Number	Description	Catalog Number
ILT Switch	6300053 (White), 6300054 (Ivory)	4 Conductor Modular Splitter	5510491
ILT - IGC Control	6300721	Single Channel Transmitter	6300879
Infrared Sensor for ILT	6150477	4 Pin Modular Connector Crimp Tool	4600020

LON CONTROLS

DESCRIPTION

LONWorks is an international standard for building management network communications. A SOMFY ILT motor paired with a Somfy LON controller can communicate with any LON certified device. The SOMFY LONWorks System provides for a flexible shading system that installs easily, is configurable without the need for rewiring, and integrates seamlessly into other building control systems.

COMPONENTS

BUS INTERFACE (BIU)

The Bus Interface Unit for ILT motors is a communication device that passes data to and from the ILT motor to switches, group controllers or other LON devices. Each BIU can control two ILT motors and provides three programmable intermediate stopping positions.

Mechanical Specifications: Overall Dimensions: L: 4 ³/₄ in. W: 5 ¹/₄ in.
D: 2 in.

Electrical Specifications: Power Supply: 48V DC (from Network), 15mA



GROUP CONTROL UNIT (GCU)

The Group Control Unit allows control of several ILT motors from a single switch. When connected to the LON busline, the GCU can be programmed to activate any Bus Interface on the busline.

Mechanical Specifications: Overall Dimensions: L: 4 ³/₄ in. W: 5 ¹/₄ in. D:
2 in.

Electrical Specifications: Power Supply: 48V DC (from Network), 15mA



LON SWITCH

This decorator switch connects to either a Bus Interface or Group Control Unit to provide local or group operation of ILT Motors. It has 6 buttons to provide UP, STOP and DOWN operation as well as 3 programmable positions. The motor limits can also be set using the same switch.

Mechanical Specifications: Overall Dimensions: L: 4 ¹/₂ in. W: 2 ³/₄ in. D: 1 ¹/₄
in.



LON BUS SUPPLY

This is a DC power supply that maintains the LON busline

Mechanical Specifications: Overall Dimensions: L: 10 in. W: 8 in.
D: 4 in.

Electrical Specifications: Input Voltage: 120V AC +/- 10%
Output Voltage: 48V DC, 0.5A



TYPICAL APPLICATION

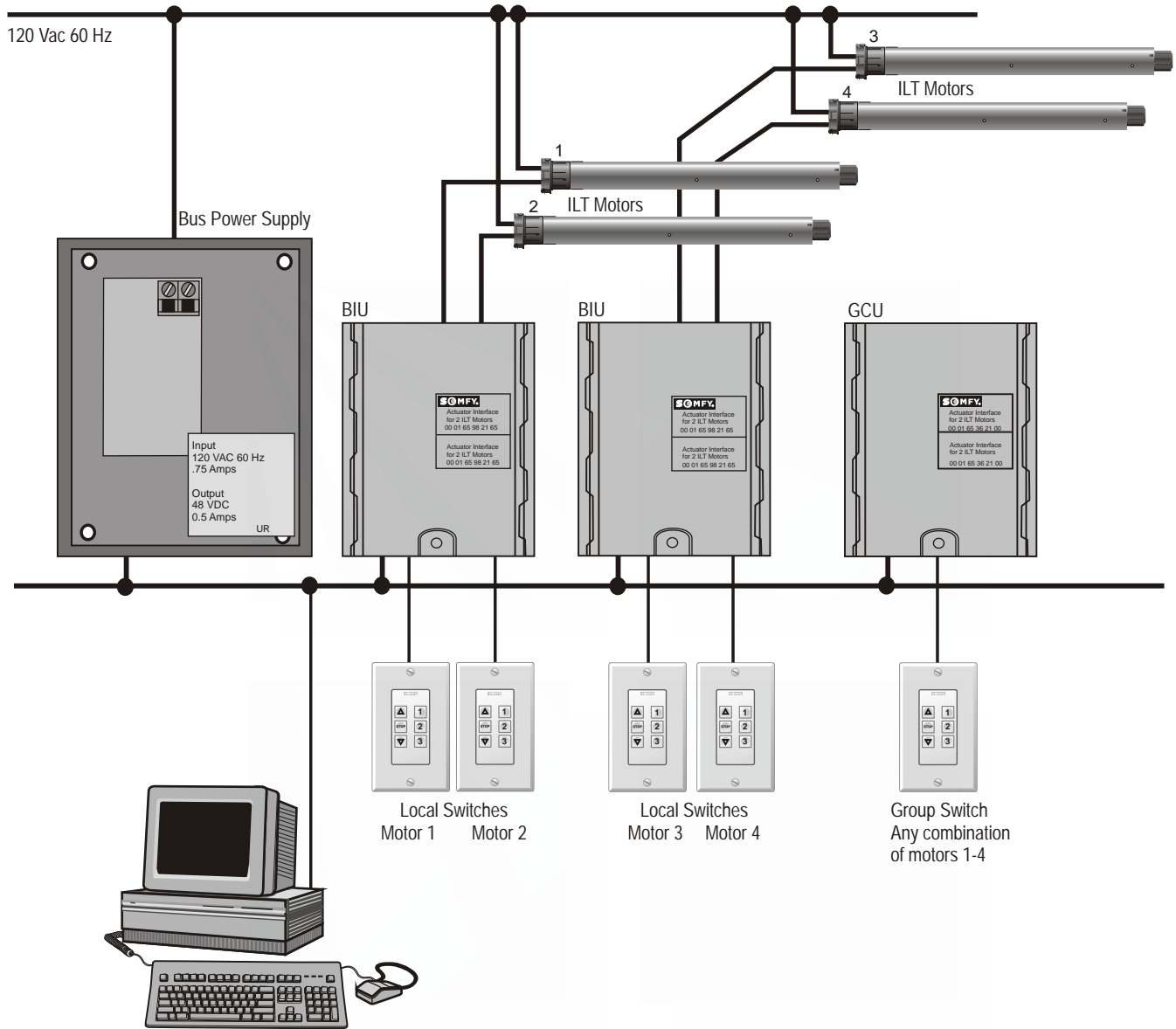

ORDERING INFORMATION

Description	Catalog Number
LON Switch	6301004 (White), 6301005 (Ivory)
Bus Interface Control	6301001
Group Control Unit	6301002
Bus Supply	6301003

SOMFY ACCESSORIES

DC TRANSFORMERS

Whenever DC motors or controls are specified, DC transformers must accompany them. Care should be taken in selecting the correct transformer for your application.

Rating	Catalog Number
12 VDC 1A	5700088
12 VDC 3A	5700091
12 VDC 5A	5700092
24 VDC 600mA	5700095
24 VDC 1A	5700093
24 VDC 1.2A	5700193
24 VDC 2.5A	5700096
24 VDC 6.5A	5700098
24 VDC 12A	5700099
24 VDC 15A	5700199
24 VDC 20A	5700200

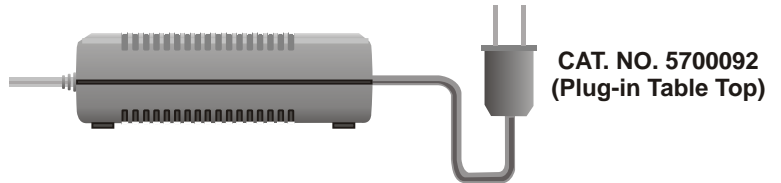

CAT. NO. 5700092
(Plug-in Table Top)



CAT. NO. 5700088
(Plug-in)

DRAPERY MOTOR CONTROLS

Description	Catalog Number
X-10 Radio Remote Control Kit	6300816
X-10 Appliance Module	6300812
X-10 Universal Module	6300747
X-10 Timer	6300815
Single Decorator Rocker Switch	6300967
Dual Decorator Rocker Switch	6300968
Decorator Switch	6301012 (White), 6301013 (Ivory)
Single Channel Infrared Remote Kit	6300876
MultiChannel Infrared Remote Kit	6300108



MOTOR TESTER CABLE

Before proceeding with line voltage wiring of any AC motor, the UP and DOWN limits should be set using the SOMFY Motor Tester Cable.

Description	Catalog Number
LT Motor Tester	6020086
FTS Motor Tester	6020087

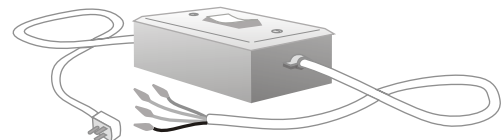

SOMFY ACCESSORIES CONT'D

MODULAR CABLE (6 Conductor)

Description	Catalog Number
Modular Cable, 2 ft., Gray	5680341
Modular Cable, 7 ft., Gray	5680278
Modular Cable, 25 ft., Gray	5680313
Modular Cable, 35 ft., Gray	5680342
Modular Cable, 50 ft., Gray	5680343
Modular Cable, 75 ft., Gray	5680345
Modular Cable, 100 ft., Gray	5680344
Modular Cable Crimping Tool (6-Pin)	4600022
Modular Cable Spool (500 ft.)	5680302
Modular Cable Spool (1000 ft.)	5680340
Modular Plug, 6-Pin	5510393
Modular Coupler, 6-Pin	5510495
Modular Tee; 1 Male to 2 Female, 6-Pin	5510496

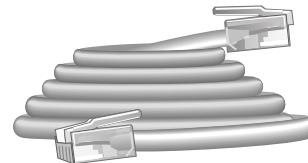

MODULAR CABLE (4 Conductor)

Description	Catalog Number
Modular Cable, 2 ft., Gray	5680401
Modular Cable, 25 ft., Gray	5680425
Modular Cable, 50 ft., Gray	5680450
Modular Cable Spool (1000 ft.)	5680404
Modular Plug, 4-Pin	5510394
Modular Cable Crimping Tool (4-Pin)	4600020

IGC TESTER CABLE KIT

This tester is used to ensure 6-pin modular connectors are correctly oriented and securely crimped onto the modular cable.
Cat. No. 6300729

ELECTRICAL BOXES

SOMFY offers masonry electrical boxes to house controls and associated wiring.

Description	Catalog Number
2 Gang Masonry Electrical Box, 3.5" Deep	5670323
4 Gang Masonry Electrical Box, 3.5" Deep	5670064
2 Gang Weatherproof Electrical Box	6110324

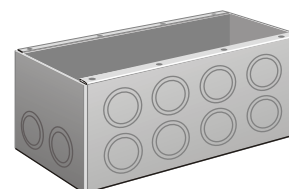



INDEX

Centralis	50	Isolation Control	65
Chronis RTS Timer	16	ILT-IGC	70
Comfort Control	40	ILT Switch	70
		Infrared Switch	19
DC-5 Control	24	IntelliS Timer	17
DC Transformers	74	IRS 300	56
Decorator RTS Switch	15		
Decorator		Key Switch	12
AC Switches	9		
DC Switches	9	LON Controls	72
Comfort Control	40	LT28 Stall Sensor	69
IGC Switch	13		
Somfy-Matic™	38	Modular Cable	75
Digital Keypad	11	Moduline	35
Drapery Motor Controls	74	Motor Tester Cable	74
Dry Contact to RTS Interface	64	MultiLink™	54
Electrical Boxes	75	Outdoor Plug-in Switch	10
Eolis Wind Control	42		
Eolis Receiver	43	RTS25-DC	52
Eolis 24V RTS Sensor	48	RTS 24V Sensors	48
		RTS Switch	15
FTS Control	68	RS232 Interfaces	62
GCS-II	26	Single Motor Remote	58
		Soliris Receiver	45
IGC	28	Soliris RTS Sensors	48
IGC-II	31	Somfy-Matic™	38
IGC/3N1	28	Sub-Group Control	34
IGC-II/3N1	31	Synchronizing Control	66
IGC-DC	22		
IGC Switch	13	Telis 1 & Telis 4 RTS Transmitters	53
IGC Sub-Group Control	34	Telis Soliris and Telis Soliris	
IGC Tester Cable	75	Patio Transmitters	47