

Motorized Soft Shade System Silent Gliss® 2050

2211

1:1

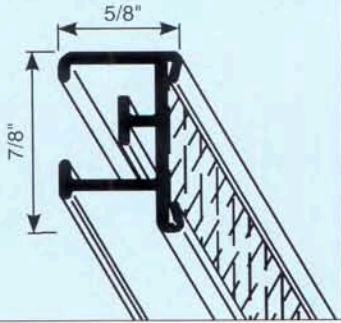

Installation Ceiling Mount

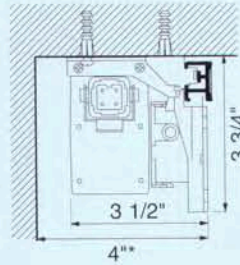

3603

Ceiling
Mount
Bracket

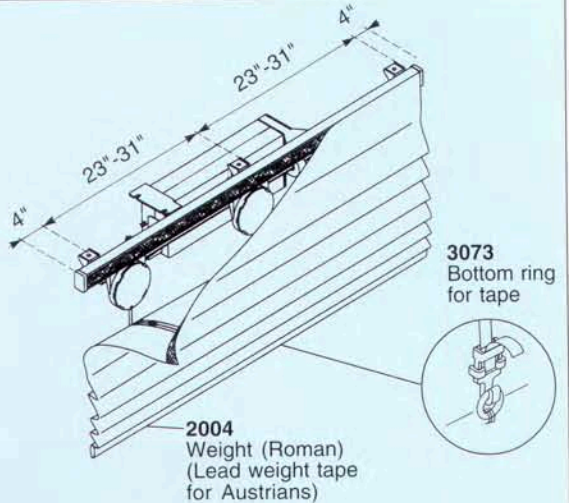

2004
Weight (Roman)
(Lead weight tape
for Austrians)

3073
Bottom ring
for tape

Wall mount with 3135/3136 + 3603

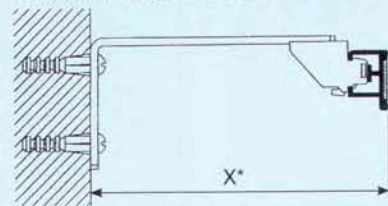

Extension bracket	X
3135	3 7/8"
3136	4 3/4"

Technical Details

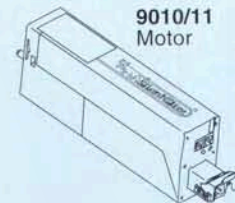

9010/11
Motor

Motor data
9010/9011
115V/60Hz/140W/
1.20Amp (3Nm)
UL Approved

Wiring Diagram
(1 motor from
1 position)

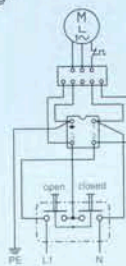

Operating Methods

Combination of wall switch /
multiple motors

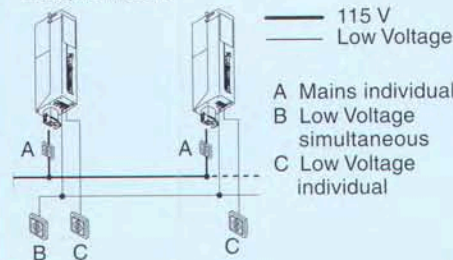

Product Information

- #2050 is a light to medium duty, motorized soft shade system for both residential and contract applications.
- Accommodates a variety of shade styles including Roman, Austrian, Balloon, etc.
- Enclosed tape reels ensure smooth, level raising and lowering of shades.
- Bottom tape rings allow adjustment of shades during installation.
- Motor is neatly concealed behind the shades headrail.
- Lift tapes may be aligned to accommodate existing shades.
- Velcro® headrail allows fast, easy removal of shades for cleaning.
- Electronic motor with built-in low voltage switching capabilities and thermal overload protection.
- Built-in low voltage interface allows direct access to all automated control systems.
- Optional infrared remote control, timer or sun sensor (see section Controls and Electrical Data).
- UL Approved.
- Suitable for shade widths up to 156" and shade heights up to 240".
- Maximum total shade weight per system, including bottom weight is 11 lbs.
- 5 Year Warranty.

Cannot be bent but universal joint 2072A available for bay windows.

Standard Accessories



Optional Accessories

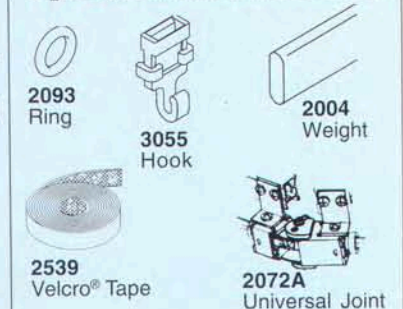

Soft Shade System Silent Gliss® 2100

2116

1:1

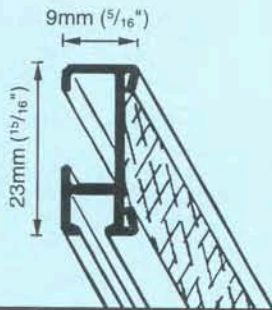

Installation

Assembly of 2100 with Eyelet 2101

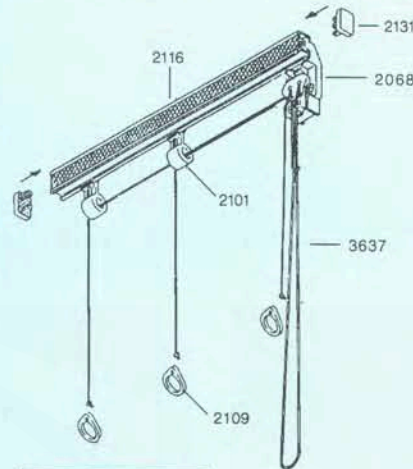

Ceiling Mount

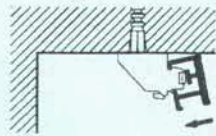

Ceiling mount with #3603 bracket

Wall Mount

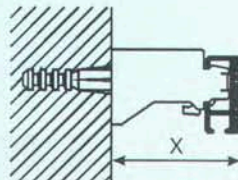

Wall mount with #3630 or #3660 bracket

Bracket	X
3630	40mm (1 9/16")
3660	70mm (2 11/16")

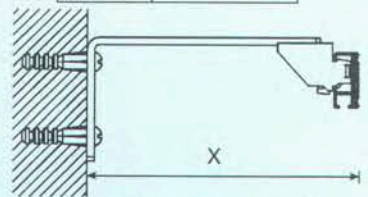

Use #0829 + #0831 extension brackets with #3603 ceiling brackets for various projections from the wall.

Extension Bracket #	X
0829	69 - 82mm (2 3/4 - 3 1/4")
0831	100 - 114mm (4 - 4 1/2")

- #2100 is a manually cord operated hardware system designed for various light weight soft shade applications such as shown below; (i.e. Roman, Russian, Austrian, Balloon and Woven Woods)

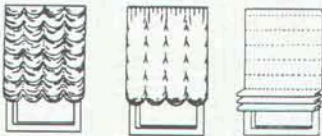

- The system can be curved for Bay and Bow windows.
- Velcro® headrail allows fast, easy removal of shade for cleaning
- System can be ceiling or wall mounted.
- Shades can be raised and lowered easily by means of a pull cord, and can be stopped at any level by means of a cord lock mechanism.
- System width up to 2.50m (8 feet)
- System height up to 3.50m (12 feet)
- Maximum Shade weight 3.0 kg (7lbs)
- 5 Year Warranty

Bending Possibilities

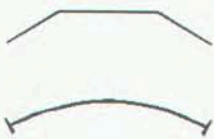

Option:
Assembly of 2100 with Wheel Pulley #2125

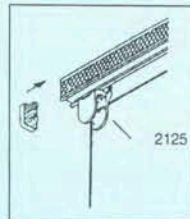

Option:
Assembly of 2100 incl Corner Connection Return #3604

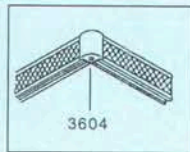

Standard Components

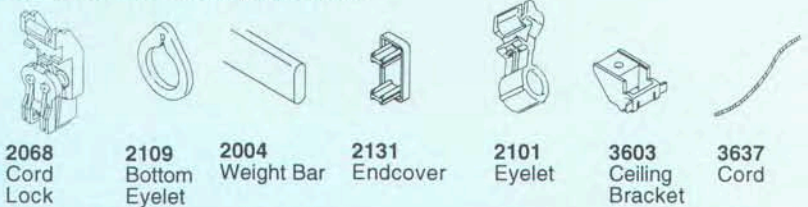

Optional Components

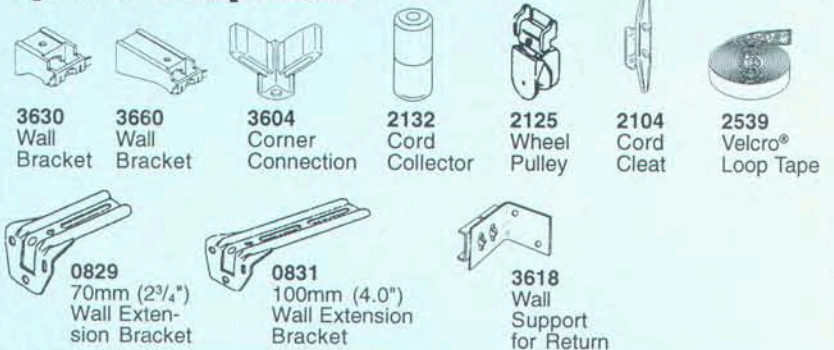

2100

Motorized Soft Shade System Silent Gliss® 2150

2151

1:2

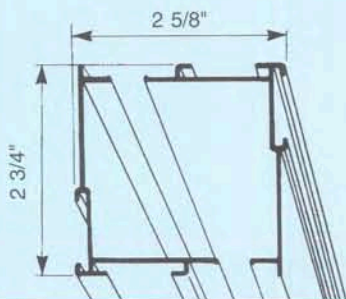

Product Information

- #2150 is a motorized soft shade system for medium to heavy duty applications

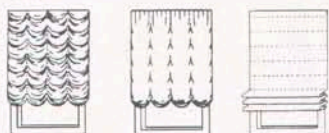

- Accommodates all types of shade styles, i.e. Roman, Austrian, Balloon, Woven Woods, etc.
- Enclosed tape spools ensure smooth, level raising and lowering of shades
- System may be angled from 0°-60° for bay windows
- Bottom tape rings allow adjustment of shades during installation
- Motor is neatly concealed in headrail box
- Lift tapes may be located to accommodate existing shades
- Velcro® headrail allows fast, easy removal of shade for cleaning
- System may be wall or ceiling mounted
- System width up to 32'
- System height up to 20'
- Maximum shade weight 90lbs
- 5 Year Warranty

Angle Possibilities

0°-60°



Installation

Ceiling Mount

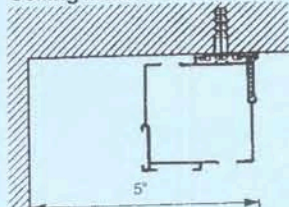

Wall Mount

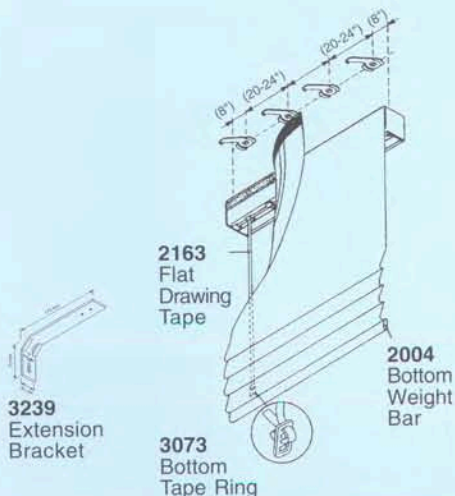
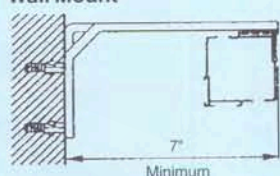

Electrical Information

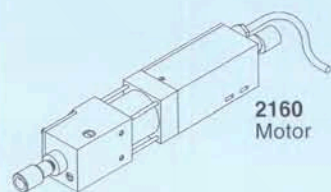

Motor Data:
UL approved
110VAC/60Hz
Torque: 2x4NM
Speed: 33RPM
1.25 AMPS
135 WATTS

Remote control

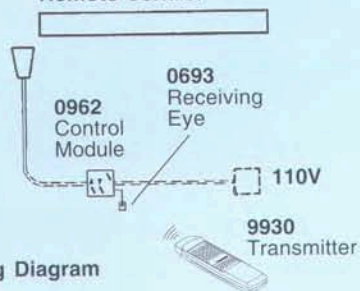

Wiring Diagram

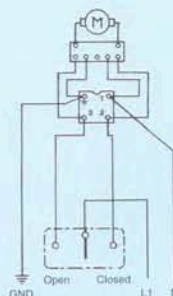

For additional information on controls and electrical wiring refer to section "Controls and Electrical Data".

Standard Components

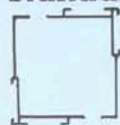

2151 Profile x 2



2160 Motor



3073 Bottom Tape Ring



2510 Velcro® strip in #2151 headrail for Velcro® tape heading



3004 Swing Clamp

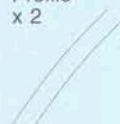

2163 Flat Lifting Tape



2004 Bottom Weight Bar



2152 Tape Spool



2154 Endcover x 2



2156 Drive Shaft



2150

Soft Shade System Silent Gliss® 2120

2211

1:1

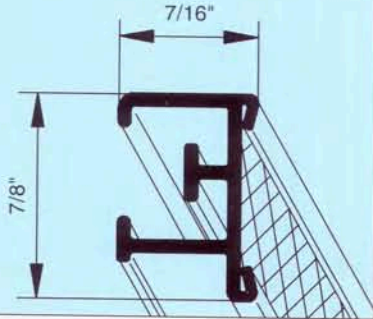

Product Information

- #2120 is a chain operated soft shade system designed for large window applications

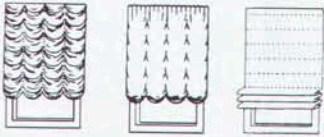

- Shades may be angled for bay windows
- Velcro® headrail allows easy removal of shade for cleaning
- Enclosed tape take-up reels keep tapes tangle free
- System can be wall or ceiling mounted
- Endless bead chain eliminates cleating of cords
- Shades may stop at any desired height, without slipping
- Maximum shade width 158"
- Maximum shade height 240"
- Maximum shade weight 18 lbs
- 5 Year Warranty

Bending Possibilities

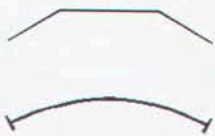

Installation

Ceiling Mount

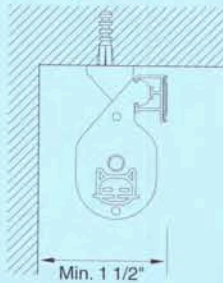

Wall Mount

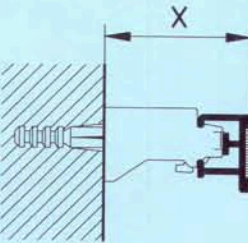

Bracket	X
3630	1 ⁹ / ₁₆ "
3660	2 ⁹ / ₁₆ "

Measurements For Bracket Installation

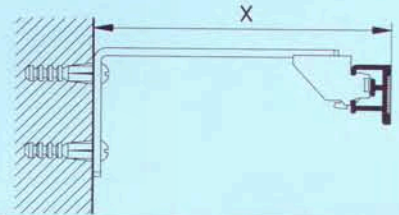
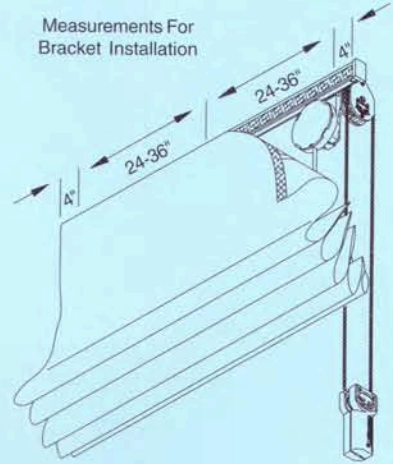

Bracket	X
0829	3"
0831	4 ³ / ₈ "

Standard Components

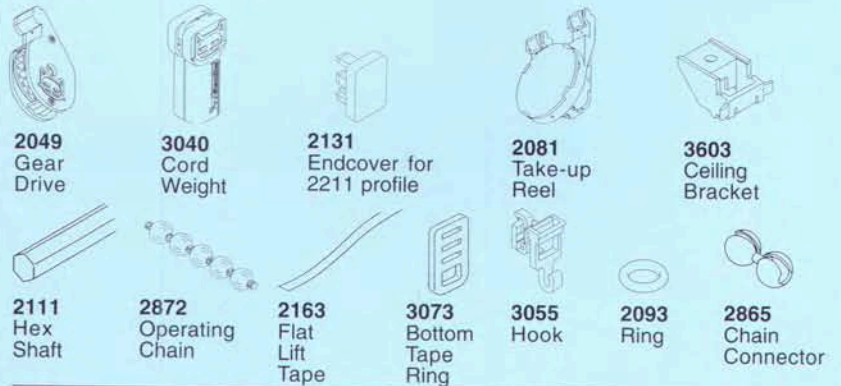

Optional Components

