



## Custom 2" NuWood™ Blind

Model #LFWOOD2

The look of wood blinds with the performance of advanced composite materials.



### KEY FEATURES:

- Look and warmth of real wood with the performance of advanced composite materials and technology
- UV stabilized polymer cap and composite formula offer superior durability and strength
- Matching valance, bottomrail, wand and tassel
- One year warranty

### PRODUCT OVERVIEW

Levolor Custom 2" NuWood™ Blinds provide the look and warmth of real wood blinds with the performance of advanced materials and technology. Levolor 2" NuWood™ blinds are easy to clean and maintain and provide excellent light control and privacy. Committed to both durability and aesthetics, the Levolor Custom 2" NuWood™ Blind combines the highest quality components with visibly attractive features to provide an overall superior product. NuWood™ is ideal for environments with high humidity, as they resist moisture and are easy to clean. The LightMaster™ privacy option, with a patent pending edge rout design, provides tighter closure, darker rooms, and increased privacy. LightMaster™ privacy option is a wise investment for NuWood™ Blinds as slats can be removed for cleaning and replacement if accidental breakage occurs.

Levolor Custom 2" NuWood™ Blinds are made from a composite formula providing strength, durability, and a scratch resistant surface. Levolor Custom 2" NuWood™ Blinds are available in ten finishes. The standard finish is a special hard polymer cap that is scratch resistant with a uniform texture and sheen that is easy to clean and maintain.

Levolor NuWood™ blinds use a proven, low profile headrail system made of roll-formed corrosion-resistant Tomized steel. The metal headrail and precision quality components provide superior support for the additional weight demands imposed by faux wood blinds. The precision molded, engineered thermoplastic drums and cradles insure accurate alignment of moving parts, smooth and maintenance-free operation.

Valance returns have a precise mitered joint secured with an easy-to-assemble return clip. The premium polymer composite slats, bottomrail, styled valance, are color coordinated with cords, ladders, wands and tassels to provide an elegant window covering.



# Custom 2" NuWood™ Blind

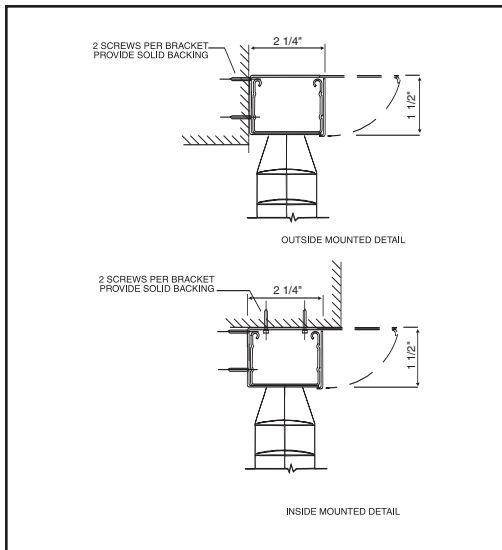
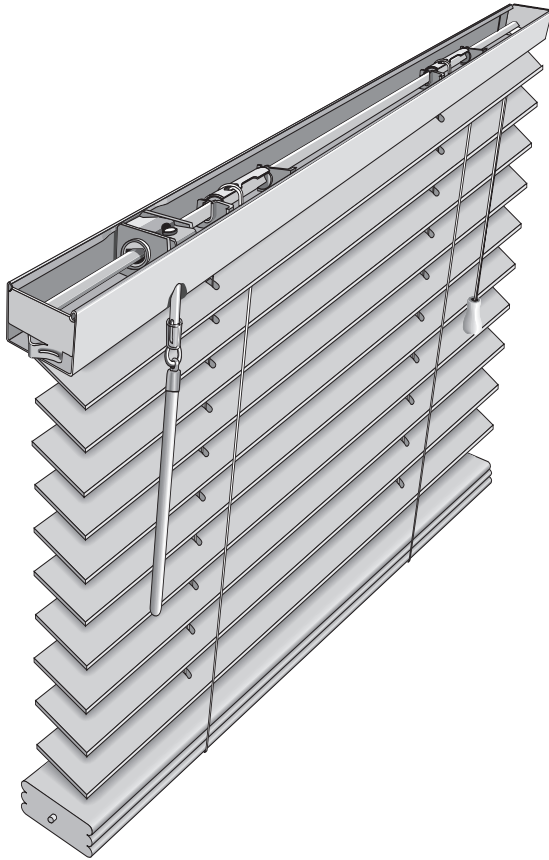

Custom 2" NuWood™ mounting detail.

## PRODUCT SPECIFICATIONS

For more detailed specifications please reference Custom 2" NuWood™ Blind product Guide Specifications.

### Part II – Products

**A. Custom 2" NuWood™ Blind manufactured by Levolor**

**B. One Year Warranty**

**C. Materials:**

- n **Headrail** shall be of .025" thick Tomized steel, "U" shaped, 1.5" high x 2-1/4" wide. All hardware shall be enclosed in the metal headrail.
- n **Tilt Wand** shall be of polymer, with a .38" diameter.
- n **Cord Lock** shall be .032" thick galvanized steel and shall be crashproof.
- n **Drum and Cradle** shall be provided for each ladder.
  - a. **Drums:**  
Traditional rout hole drums are .020" thick galvanized steel. Cloth tape drums are injection molded thermoplastic.
  - b. **Cradles** are injection molded thermoplastic.
- n **Installation Brackets** shall be of at least .040" thick Tomized steel with a rivet-hinged safety locking front cover to permit removal of headrail without lateral movement.
- n **Ladders** (slat supports): Distance between 2" slats shall not exceed 44 mm (nominally 6.9 slats per vertical foot).
- n **Slats** shall be of polymer composite formula with UV stabilized cap with a consistent texture and sheen selected from available Levolor Custom NuWood™ colors . Maximum slat length is 96". Standard 2" slats are nominally 2" wide x 1/8" high.
- n **Bottomrail** shall be nominally 2" wide x 5/8" high and finished to coordinate with slats.
- n **Options** shall include:
  - a. Cord Tilter
  - b. Twill Tapes
  - c. LightMaster™ privacy feature



Levolor Contract  
4110 Premier Drive  
High Point, NC 27265

Contract Customer Service  
1-800-826-8021  
[www.levolorcontract.com](http://www.levolorcontract.com)

© Copyright 2004 Levolor Home Fashions. All rights reserved. US and non-US patents and patents pending. Product specifications are subject to change without notice. Printed in the USA.

R0203154