

# HunterDouglas

## Installation • Operation • Care

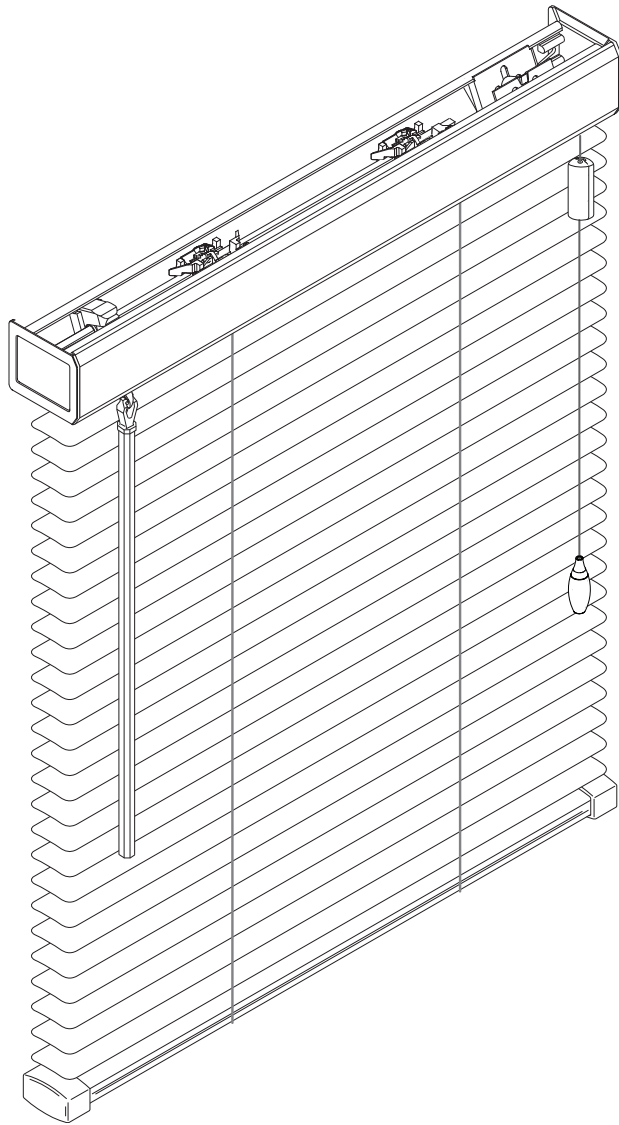

**THANK YOU** for purchasing a Hunter Douglas blind. Your new blind has been custom built for you from the highest quality materials. Once in your window, it will provide you with a lifetime of beauty and trouble-free use.

### Getting Started

- Remove the blind from the package. Keep the packaging until the blind operates to your satisfaction.
- Check the diagram to make sure you have the necessary parts.
- Contents of your hardware package may vary depending upon mounting options chosen.

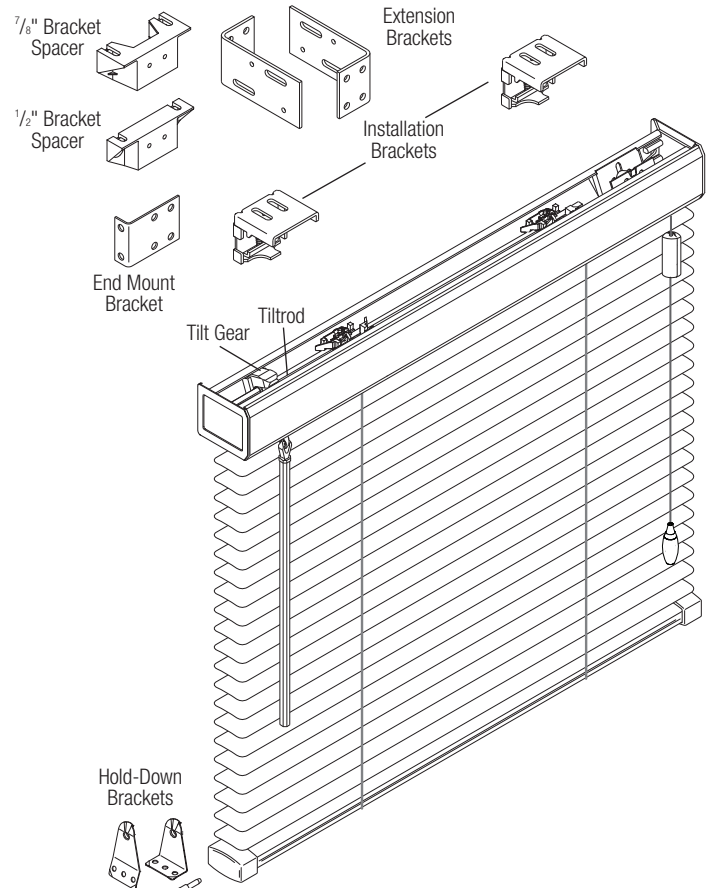

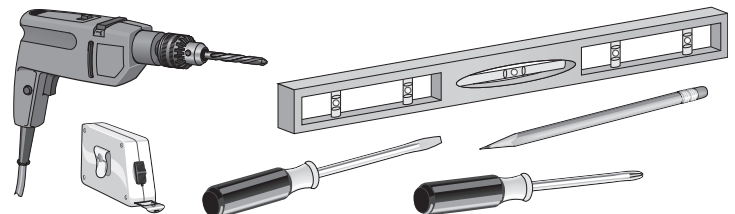

### Tools needed for installing your blind

- Measuring tape
- Carpenter's level
- Pencil
- Flat blade screwdriver
- Power drill, 1/4" hex driver and drill bits
- Phillips screwdriver



In addition, you may need fasteners designed to work with your specific mounting surfaces:

Mounting Surface	Fastener
Drywall, Plaster	Wall Anchors, Expansion Bolts (Not Provided) 
Metal	Sheet Metal Screws (Not Provided) 
Wood	No. 6 Hex Head Screws (Provided) 

## 1/2" and 1" Horizontal Aluminum Blinds

For assistance, call the Hunter Douglas  
Customer Information Center  
at 1-888-501-8364  
Visit our Web site at [hunterdouglas.com](http://hunterdouglas.com)

# 1 Mount the Brackets

## Bracket Spacing

- Position the two end brackets on the mounting surface so that they will be located between 2" and 6" from the ends of the headrail.
- If more brackets are required (see chart below), space the additional bracket(s) evenly between the end brackets.

Blind Width	Under 60 Sq. Ft.	60 Sq. Ft. and Over
7" – 60"	2	3
60 1/8" – 120"	3	4
Over 120"	4	5

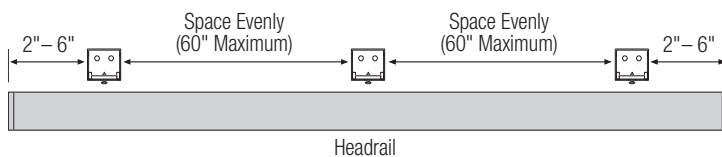

**IMPORTANT:** Do not position any bracket where it will be located directly above a string ladder, cordlock or wand tilter. Allow 1" space on the side whenever possible.

- If the blind is larger than 60 square feet, position an extra bracket at the cordlock end for added support when raising the blind. With Two-On-One headrail blinds, position an extra bracket near each cordlock.

## Inside Mount Applications

Use a carpenter's level to check that the mounting surface is perfectly level. Shim the installation brackets, if necessary.

- A minimum casement depth of 7/8" is required for bracket attachment.
- A depth of 1 3/4" is required to fully recess the blind.

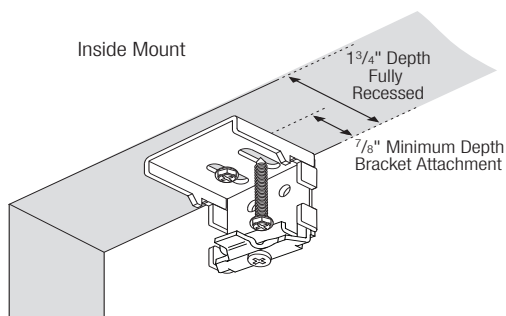

## Inside Mount Bracket Attachment

- Attach the installation brackets with two screws through the two holes in the top of the brackets.
- Be sure the front edges of the brackets are aligned before tightening the screws.

## Outside Mount Applications

A flat vertical surface at least 5/8" high is required for bracket attachment.

### Outside Mount Bracket Attachment

- Attach the installation brackets with two screws through the two holes in the rear of the brackets.
- Use a carpenter's level to check that the tops of the brackets are aligned at the same height before tightening the screws.

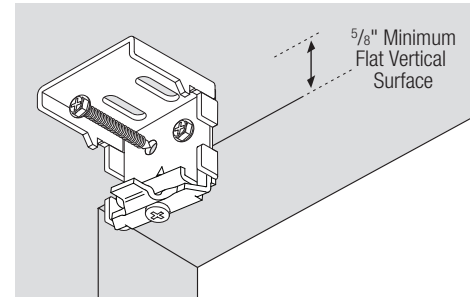

### Extension Brackets (Optional)

Extension brackets can be used with outside mounts to project the installation brackets from 2 3/4" to 4 1/8" from the mounting surface. This allows for additional clearance of obstructions such as window cranks or handles.

- The extension brackets may be fastened together two different ways to produce the desired wall extension, as shown below.
- Attach the extension brackets using No. 6 self-tapping screws.

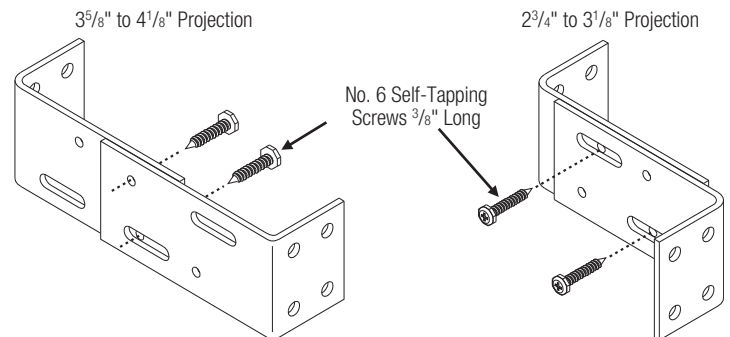

- Mount the extension bracket assemblies to the window frame or wall using two diagonally located screws.
- Use appropriate fasteners to bolt the mounting brackets to the extension brackets.

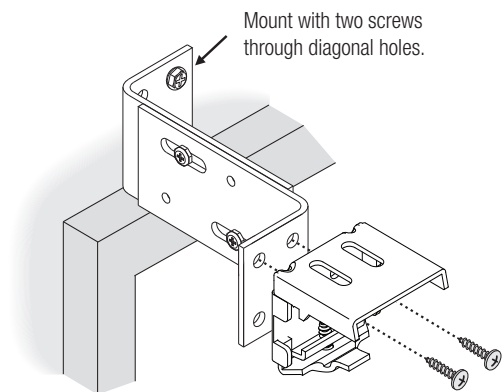

### Bracket Spacers (Optional)

Bracket spacers can also be used to add clearance. Two versions are available: 1/2" and 7/8".

- Attach the spacers to the installation brackets using the two screws provided with each spacer.

# 3 Complete the Installation

## Attach the Wand Tilter

The tilt mechanism inside the headrail has a metal shaft that extends beneath the rail. The wand tilter must be attached to this shaft. There are two types of wands — hook and snap-on.

- **Hook wand:** Remove the plastic sleeve from the top of the wand, slide it over the metal shaft, insert the wand hook over the hole in the shaft, and slide the sleeve over the hook to complete the wand installation.
- **Snap-on wand:** Push up until the snap-on connector snaps into place, through the hole in the shaft.
- Test the wand tilter by tilting the slats fully closed up and fully closed down.

### Hook Wand

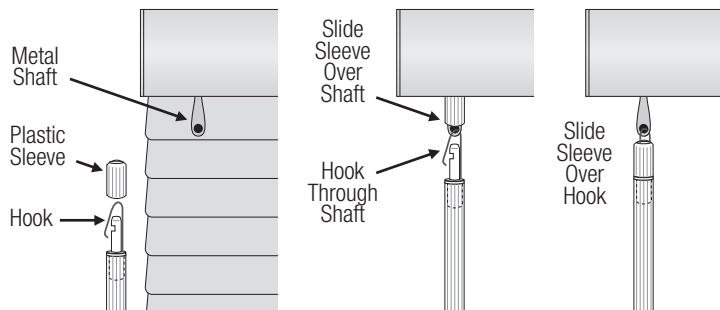

### Snap-on Wand

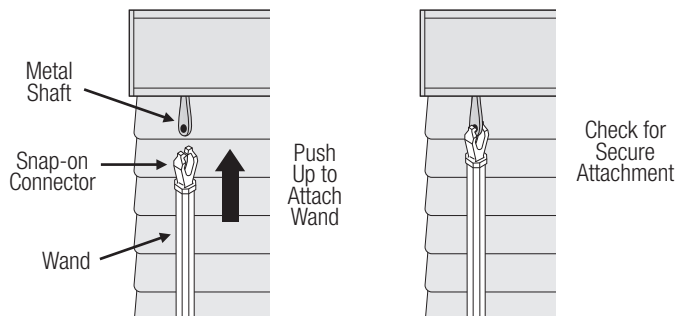

## Attach Hold-Down Brackets (Optional)

### Metal Hold-Down Brackets

- Insert a hold-down pin into each of the bottom rail end caps.
- Attach the hold-down brackets to the jamb, sill, or outside mounting surface. When the blind is fully lowered, the holes in the hold-down brackets must align with the pins in the bottom rail end caps.
- Insert the pins into the holes in the hold-down brackets.

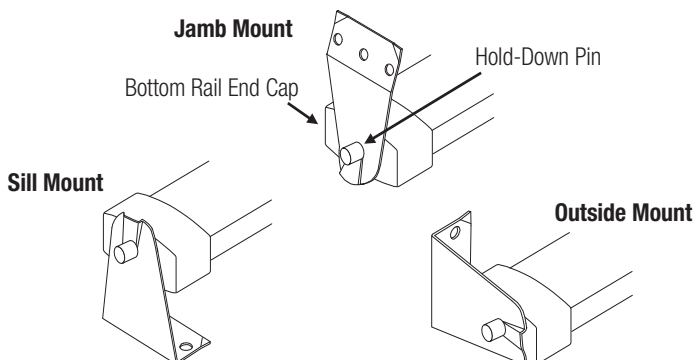

# 4 Operate the Blind

## Tilting the Slats

After installation, rotate the wand to tilt the slats from fully closed in one direction to fully closed in the other.

## Raising and Lowering the Blind

- Pull the cords down and toward the center to raise and lower. The slats should be open when raising and lowering.
- Pull the cords to the outside to lock the blind in position.

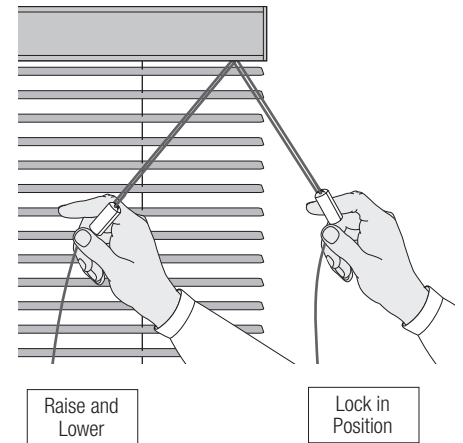

# 5 Care and Cleaning

- Dust with a soft, clean cloth or chemically treated dust cloth. Tilt the slats up and dust. Then tilt the slats down (but not all the way closed) and dust the other side of the slats.
- Vacuum using the brush dust head attachment and tilt the slats up and down as described for dusting.
- Wash slats using a damp cloth and mild detergent solution. Use warm or cold water, not hot water. Tilt the slats up and down as described for dusting.
- Bottom rail and slats may also be immersed in a bathtub for a more thorough cleaning. Do not immerse the headrail. Place the blind in a solution of mild, soapy water. Rinse clean and either wipe dry or allow to air dry completely.

# 6 Child Safety



**! WARNING**

For more safety information call 1-888-501-8364 in the U.S. or 1-866-662-0666 in Canada.

Young children can STRANGLE in cord loops and in the loop above the cord stop. They can also wrap cords around their necks and STRANGLE. In addition, inner cords can pull out to form a loop, which can STRANGLE a young child.

- Always keep cords out of children's reach.
- Move cribs, playpens and other furniture away from cords. Children can climb furniture to get to cords.
- Do not tie cords together. Make sure cords do not twist together to create a loop.

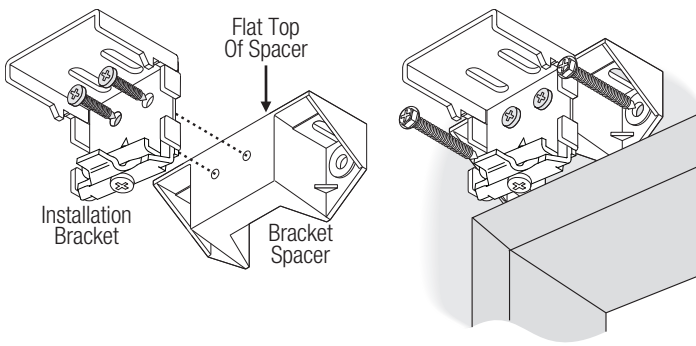

- Attach the installation brackets to the mounting surface with screws through the two holes in the rear of the bracket spacers.
- Use a carpenter's level to check that the tops of the brackets are aligned at the same height before tightening the screws.

## End Mount Applications

End mounting is used when the headrail must span an open space — an arched window opening, for example.

### End Mount Bracket Attachment

- Attach the short side of the end mount brackets to the mounting surface with two screws.
- Be sure the two end mount brackets are aligned at the same height.
- Attach the installation brackets with screws through the top two holes on the end mount brackets.

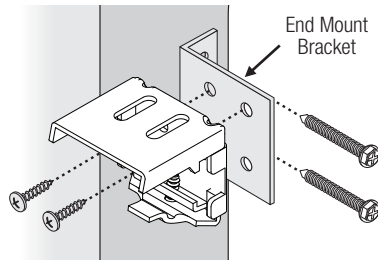

# 2 Install the Blind

## Mount the Headrail

- Tilt back the headrail and slide it into the bracket on the sloped tab. There are two possible headrail designs, each of which is illustrated below.
- Position the back lip of the headrail behind the rear leg of the installation bracket.
- Tighten the locking screw to hold the rail securely in place.

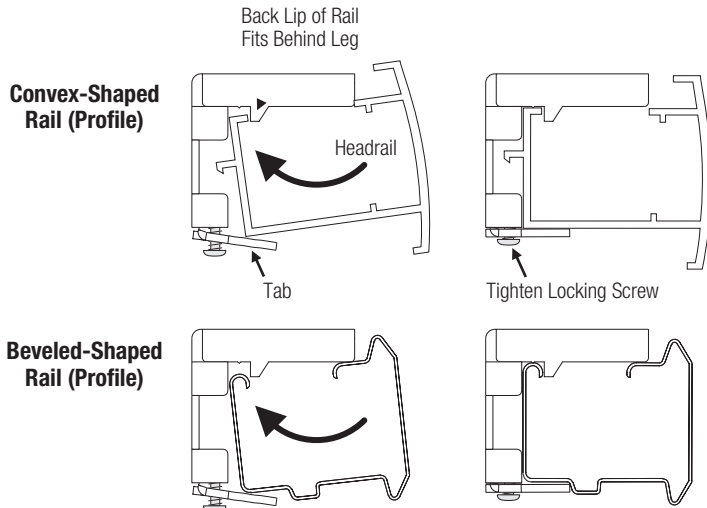

- To remove the headrail, first loosen the locking screw. Then tilt the headrail back and slide it out of the installation brackets.

## Cord Stop

- This component acts as a stopper to prevent inner cords from being pulled through the blind, which can pose the risk of entanglement.
- It is also designed to break apart under significant pressure, which may lessen the risk of entanglement in the top lift cords.

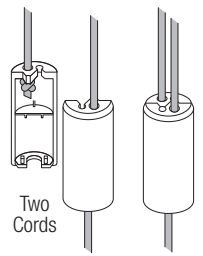

## Reassembly of Cord Stop

- Reinsert any loose cords into the top notches of the cord stop. There is a notch on each side.
- Line up the two halves of the cord stop and snap the pieces back together.

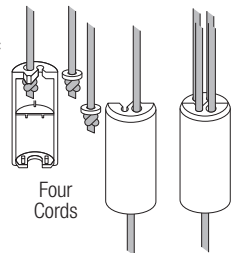

## Cord Cleats

Hunter Douglas offers cord cleats and we recommend their use.

- Attach two cord cleats 6" to 12" apart at a height where they will be out of the reach of children. Take into account that a child may stand on furniture attempting to reach the cords. Be sure the cleats are firmly secured.
- Once the cleats are attached, wrap excess cord around them after each use of the blind.



# 7 Troubleshooting

PROBLEM	SOLUTION
The blind does not raise and lower evenly.	Check inside the headrail. Make sure no obstructions keep the mechanism from turning. Check that the lift cords are not pinched or tangled.
The lift cord is wrapped around the ladder tape.	Remove the plastic cap on the bottom of the blind that covers the cord rout hole. Untie knot in lift cord and re-thread. Re-tie the knot and replace cap.
The blind does not tilt.	Remove blind from brackets. Check inside the headrail to ensure the tiltrod is fully inserted into the tilt gear.



# HunterDouglas

LIGHT CAN CHANGE EVERYTHING®

[hunterdouglas.com](http://hunterdouglas.com)

© 2008 Hunter Douglas Inc. ® Registered trademark of Hunter Douglas Inc. Patented in the U.S. and foreign countries. U.S. and foreign patents pending.



Product Code No. 5109609000

4/08 D